

Norfolk Vanguard Offshore Wind Farm Outline Access Management Plan

Applicant: Norfolk Vanguard Limited
Document Reference: 8.10
APFP Regulation: 5(2)(q)

Date: January 2019
Revision: Version 2
Author: Royal HaskoningDHV

Photo: Kentish Flats Offshore Wind Farm



Date	Issue No.	Remarks / Reason for Issue	Author	Checked	Approved
04/05/18	01D	First draft for Norfolk Vanguard Limited review	PC/AR	ST	AH
05/06/18	01F	Final submission	PC/AR	ST	AH
25/01/19	02D	Updates for Deadline 2	PC/AR	ST	AH

Table of Contents

1	Outline Access Management plan	1
1.1	Introduction	1
1.2	Purpose of the OAMP	2
1.3	Consultation	3
1.4	Project Description	3
1.5	Access Strategy	5
1.6	Access Design	13
1.7	References	24
1.8	Figures	25
	Appendix 1: A47 Access Technical Note	26
	Appendix 2: Access Design Concepts.....	27

Figures

Figure 1 Project study area

Figure 2 Stage 2 Onshore Project Infrastructure Sites

Tables

Table 1.1 Embedded mitigation	4
Table 1.2 Indicative project construction programme (HVDC Two Phase)	5
Table 1.3 Access location and function	8
Table 1.4 Access review	17

Glossary

AADT	Annual Average Daily Traffic
AMP	Access Management Plan
DCO	Development Consent Order
DMRB	Design Manual for Roads and Bridges
EIA	Environmental Impact Assessment
ES	Environmental Statement
HDD	Horizontal Direction Drilling
HDPE	High Density Polyethylene
HE	Highways England
HGV	Heavy Goods Vehicle
HVDC	High Voltage Direct Current
MA	Mobilisation Area
OAMP	Outline Access Management Plan
OTMP	Outline Traffic Management Plan
OTP	Outline Travel Plan
PEIR	Preliminary Environmental Information Report
TC	Trenchless Crossing

Terminology

Cable Relay Station	Primarily comprised of an outdoor compound containing reactors (also called inductors, or coils) and switchgear to increase the power transfer capability of the cables under the HVAC technology scenario as considered in the PEIR. This is no longer required for the project as the HVDC technology has been selected.
Control Point	A location that provides the checks and controls for the movement of HGVs and employees.
Delivery	A delivery is the process of transporting goods from a source location to a predefined destination. A delivery will generate two vehicle movements (an arrival and departure)
Jointing pit	Underground structures constructed at regular intervals along the cable route to join sections of cable and facilitate installation of the cables into the buried ducts.
Landfall	Where the offshore cables come ashore at Happisburgh South
Landfall compound	Compound at landfall within which HDD drilling would take place
Link boxes	Underground chambers or above ground cabinets next to the cable trench housing low voltage electrical earthing links.
Mobilisation area	Areas approximately 100 x 100m used as access points to the running track for duct installation. Required to store equipment and provide welfare facilities. Located adjacent to the onshore cable route, accessible from local highways network and suitable for the delivery of heavy and oversized materials and equipment.
National Grid new / replacement overhead line tower	New overhead line towers to be installed at the Necton National Grid substation.
National Grid overhead line modifications	The works to be undertaken to complete the necessary modification to the existing 400kV overhead lines
National Grid substation	The permanent footprint of the National Grid substation extension

extension	
National Grid temporary works area	Land adjacent to the Necton National Grid substation which would be temporarily required during construction of the National Grid substation extension.
Necton National Grid substation	The existing 400kV substation at Necton, which will be the grid connection location for Norfolk Vanguard
Onshore 400kV cable route	Buried high-voltage cables linking the onshore project substation to the Necton National Grid substation
Onshore cable route	The 45m easement which will contain the buried export cables as well as the temporary running track, topsoil storage and excavated material during construction.
Onshore cables	The cables which take the electricity from landfall to the onshore project substation.
Onshore infrastructure	The combined name for all onshore infrastructure associated with the project from landfall to grid connection.
Onshore project area	All onshore electrical infrastructure (landfall; onshore cable route, accesses, trenchless crossing technique (e.g. Horizontal Directional Drilling (HDD)) zones and mobilisation areas; onshore project substation and extension to the Necton National Grid substation and overhead line modification)
Onshore project substation	A compound containing electrical equipment to enable connection to the National Grid. The substation will convert the exported power from HVDC to HVAC, to 400kV (grid voltage). This also contains equipment to help maintain stable grid voltage.
Running track	The track along the onshore cable route which the construction traffic would use to access workfronts.
The Applicant	Norfolk Vanguard Limited
The project	Norfolk Vanguard Offshore Wind Farm, including the onshore and offshore infrastructure.
Transition pit	Underground structures that house the joints between the offshore export cables and the onshore cables.
Trenchless crossing zone (e.g. HDD)	Temporary areas required for trenchless crossing works.
Vehicle movement	A single trip (i.e. either an arrival to, or departure from site) for the transfer of employees or goods.
Workfront	The 150m length of onshore cable route within which duct installation would occur

1 OUTLINE ACCESS MANAGEMENT PLAN

1.1 Introduction

1. This document forms part of the Development Consent Order (DCO) application for the onshore project area for the Norfolk Vanguard Offshore Wind Farm (hereafter 'the project').
2. A traffic and transport impact assessment has been undertaken for the project and is detailed in Chapter 24 Traffic and Transport of the Environmental Statement (ES).
3. In respect of traffic and transport, the certified plans referred to in the DCO are outlined below:
 - Outline Traffic Management Plan (OTMP) (document reference 8.8): The OTMP sets out the standards and procedures for managing the impact of Heavy Goods Vehicles (HGV) traffic during the onshore construction period, including localised road improvements necessary to facilitate the safe use of the existing road network;
 - Outline Travel Plan (OTP) (document reference 8.9): The OTP sets out how onshore construction employee traffic would be managed and controlled; and
 - Outline Access Management Plan (OAMP) (document reference 8.10): The OAMP sets out detail on the location, frontage, general layout, visibility and embedded mitigation measures for access for the onshore project substation, landfall and points of access to the onshore cable route. It presents the requirements and standards that will be incorporated into the final access design.
4. Final plans which accord with these outline documents must be submitted to and approved by the relevant local planning authority (in consultation with Norfolk County Council and Highways England) prior to commencement of any relevant works, as per Requirement 22 of the draft DCO.
5. This OAMP is complimented by the OTMP which details additional measures to facilitate vehicles (particularly HGVs) to safely access the main distributor highway network via the identified access tracks and minor routes during the onshore construction period.
6. Following appointment of a contractor, the measures outlined in the respective plans would be validated and optimised in consultation with Norfolk County Council and Highways England.
7. Norfolk Vanguard Limited is seeking consent for the following onshore elements of the project:

- Landfall;
 - Onshore cable route, accesses, trenchless crossing (e.g. Horizontal Directional Drilling (HDD)) zones and mobilisation areas;
 - Onshore project substation; and
 - Extension to the Necton National Grid substation and overhead line modifications.
8. The applicant is also developing Norfolk Boreas, a ‘sister project’ to Norfolk Vanguard. Norfolk Boreas would share a grid connection location and also much of the offshore and onshore cable corridors with Norfolk Vanguard. Therefore, in order to minimise impacts, Norfolk Vanguard Limited will include within its Development Consent Order (DCO) application some enabling works for the Norfolk Boreas project (subject to Norfolk Boreas DCO and Financial Investment Decision), these include:
- Installation of ducts to house the Norfolk Boreas export cables, along the entirety of the onshore cable route from the landward side of the landfall transition pit to the Norfolk Boreas’ onshore project substation; and
 - Modification of the existing overhead lines in the vicinity of the Necton National Grid substation for Norfolk Vanguard and Norfolk Boreas.
9. The scope of the OAMP covers all the public highway access requirements for the construction phase of the onshore elements of the project and the operational phase of the onshore project substation permanent access.
10. During the operational phase, for the remaining onshore project elements, traffic movements would be limited to periodic maintenance at the link boxes/test pits along the onshore cable route. Due to the limited nature of these operations, the OAMP does not consider operational access for the onshore cable route.

1.2 Purpose of the OAMP

11. The purpose of the OAMP is to set out details on the location, general layout, visibility and embedded mitigation measures for access for the onshore project substation, and points of access to the onshore cable route.
12. The OAMP presents the requirements and standards that will be incorporated into the final Access Management Plan (AMP) pursuant to the discharge of Requirement 22 of the DCO.
13. Norfolk Vanguard Limited would define performance standards to be observed as part of the Contractor’s obligations to comply with and observe the Requirements 21 and 22 of the DCO.
14. Norfolk Vanguard Limited will work with the relevant Local Authorities to ensure that the provisions set out in the OAMP are adhered to.

1.3 Consultation

15. Norfolk Vanguard Limited has undertaken pre-application consultation on the project in accordance with the requirements of the Planning Act 2008.
16. To date, consultation regarding traffic and transport has been conducted through transport specific Expert Topic Group (ETG) meetings in January 2016, July 2017 and January 2018 to review and agree methodologies for the assessments, the Scoping Report (Royal HaskoningDHV, 2016) and the Preliminary Environmental Information Report (PEIR) (Norfolk Vanguard Limited, 2017). The ETG included transportation professionals from Norfolk County Council (NCC), Highways England (HE) and Norfolk Vanguard Limited. Whilst not a member of the ETG, Suffolk County Council were kept informed of developments, noting that the south east tip of the traffic and transport study area encompassed two roads within their administration area.
17. Further details of consultation undertaken to date is outlined within Chapter 24 Traffic and Transport of the ES.

1.4 Project Description

18. A comprehensive project description of the onshore project area is contained within Chapter 5 Project Description of the ES.
19. The onshore cable route is approximately 60km in length and travels west from the landfall at Happisburgh South towards the northern edge of North Walsham before bearing southwest to the onshore project substation at Necton as shown in Figure 1.
20. The onshore project substation at Necton will be constructed approximately 1km away from the existing Necton National Grid substation.
21. The onshore cable route would require trenches (within which ducts would be installed to house the cable circuits); a running track to deliver equipment to the installation site from mobilisation areas, and separate storage areas for topsoil and subsoil.
22. The main installation method would be through the use of open cut trenching. High Density Polyethylene (HDPE) ducts would be installed within the trenches and the soil backfilled. Cables would then be pulled through the pre-laid ducts at a later stage in the programme.

1.4.1 Embedded Mitigation

23. Norfolk Vanguard Limited has committed to a number of techniques and engineering designs/modifications as part of the project, during the pre-application phase, in order to avoid a number of impacts or reduce impacts as far as possible. Embedding

mitigation into the project design is a type of primary mitigation and is an inherent aspect of the EIA process.

24. Full details of the embedded mitigation can be found within Chapter 5 Project description of the ES.
25. Table 1.1 sets out the designed in (embedded) mitigation measures that have been applied to the traffic forecasts contained in this OAMP.

Table 1.1 Embedded mitigation

Parameter	Mitigation measures embedded into the project design	Notes
Trenchless Crossings	<p>Commitment to trenchless crossing techniques at key sensitive environmental features, including but not limited to; waterways, protected wildlife sites, woodlands, long distance cycle route/footpaths, and major transport corridors to avoid significant environmental disturbance. These include avoiding specific features such as;</p> <ul style="list-style-type: none"> • Trunk Roads including A47, A140, A149; • Mid-Norfolk Railway; and • Network Rail. 	<p>A commitment to a number of trenchless crossings at some sensitive locations has been a project commitment from the outset. However, in light of consultation received during PEIR Norfolk Vanguard Limited has committed to additional trenchless crossings as a direct response to stakeholder requests.</p>
Mobilisation Areas	<p>Mobilisation areas would be located close to main A-roads minimising impacts upon local communities and utilising the most suitable roads.</p> <p>Mobilisation areas located away from population centres where practical to reduce impact on local communities and population centres.</p>	
Duct Installation	<p>Suitable access points and identification of optimum routes for construction traffic to use. This minimises impacts on sensitive receptors</p>	<p>Details contained within the OAMP (document reference 8.10)</p>
Cable Pull and Jointing Stage access	<p>Suitable side accesses and road crossing locations reviewed from initial schedule of 200+ access points to 76 realistic potential access points to minimise local route impacts.</p>	<p>Details contained within in the OAMP (document reference 8.10)</p>
Vehicle Movement	<p>Construction of an (up to) 6m wide running track with an approximate length of 60km. This would reduce the number of access points required and HGV movements on the local road network.</p> <p>Consolidating HGVs at mobilisation areas to reduce vehicle movements along more sensitive local routes.</p> <p>Carefully selected delivery routes acknowledging the sensitive receptors within the study area</p>	<p>Details contained within the OTMP (document reference 8.8)</p>

Parameter	Mitigation measures embedded into the project design	Notes
	Management measures to control timing deliveries	
Onshore Cable Route Site Selection	Consolidating onshore cable route section construction employee movements at mobilisation areas. Onward travel along the running track to place of work reducing vehicle movements along local routes.	Details contained in the OTP (document reference 8.9)

1.5 Access Strategy

26. The onshore cable route, landfall and onshore project substation access strategy has been developed to support the discrete stages of the project’s construction phase which are:
- Stage 1: Pre-construction works e.g. pre-construction surveys;
 - Stage 2: Duct installation works, landfall and onshore project substation primary works (including National Grid substation extension); and
 - Stage 3: Cable pull, joint and commission.
27. The project could be constructed in either two phases or one continuous construction phase (up to 1,800MW). For the purposes of the ES assessment a worst case scenario of the two phase approach was adopted.
28. The access strategy has also been developed to accommodate the operational phase for the onshore project substation. Table 1.2 details an indicative construction phase programme for the project.

Table 1.2 Indicative project construction programme (HVDC Two Phase)

Activity	Year					
	2020	2021	2022	2023	2024	2025
Landfall						
Duct Installation						
Cable Pull, Joint and Commission						
<i>Phase 1</i>						
<i>Phase 2</i>						
Onshore cable route						
Pre-construction works						
Duct installation works						
Cable pull, joint and commission						
<i>Phase 1</i>						
<i>Phase 2</i>						
Onshore project substation						

Activity	Year					
	2020	2021	2022	2023	2024	2025
Pre-construction works						
Primary works						
Electrical plant installation and commission						
<i>Phase 1</i>						
<i>Phase 2</i>						

1.5.1 Stage 1: Preconstruction works

29. The pre-construction stage represents a number of activities with limited traffic demand e.g. pre-construction surveys. Access to the onshore project area would be via existing tracks, however some new accesses may be constructed during this phase to facilitate construction at stage 2.

1.5.2 Stage 2: Duct installation works and onshore project substation primary works

30. The access strategy for stage 2 has been developed to accommodate the following requirements:

- Access to mobilisation areas (MA);
- Road crossing of the highway by the project 'running track'; and
- Side access to trenchless crossing technique (e.g. HDD) locations.

31. Figure 2 details the key components of stage 2 construction phase.

32. The onshore duct installation and onshore project substation primary works are serviced by 14 mobilisation areas. The main function of the mobilisation areas is to provide a control point for HGVs delivering to the onshore cable route, as well as providing welfare facilities, parking for staff and storage areas for materials, plant and equipment.

33. The mobilisation areas are located in close proximity to A roads and B roads to concentrate traffic demand away from minor routes. They are located away from settlements to minimise disruption to local communities.

34. The onshore cable route has been separated into 20 cable route sections, which would be accessed from the mobilisation areas via a running track. The running track would provide safe access for construction vehicles along the onshore cable route, from mobilisation areas to duct installation sites and would serve to significantly reduce the number of trips on the local highway network.

35. The running track will be up to 6m wide and would extend the full length of the onshore cable route crossing the public highway in a number of locations.
36. There are a number of physical features which cannot be disturbed by trenching methods or the running track; examples of this include rivers and railway lines. To install the onshore cable route across such features a trenchless crossing technique¹ would be employed.
37. Each trenchless crossing location would require access to the 'drive' and 'reception' zone of the crossing. Access would be via the running track in the majority of cases, however some locations may be totally 'land locked' and therefore require direct access either via a private track from the public highway, referred to as a 'side access' or via a road crossing direct into the cable route.

1.5.3 Stage 3: Cable pull, joint and commission

38. Cables would be pulled through the installed ducts later in the construction programme in an approach of up to two phases. This approach would allow the main civil works to be completed in advance of cable delivery, preventing the requirement to re-open the land on a wholesale basis.
39. Cable pulling would not require the trenches to be re-opened. The cables would be pulled through the pre-installed ducts (installed during the duct installation works) at jointing pit locations located along the onshore cable route. The jointing pits and associated accesses would be constructed during the cable pull phase which would facilitate the cable pulling activities.
40. This would be achieved through access to the onshore cable route directly from the highway network (at running track crossing locations) or existing local access routes where possible. In some locations, isolated sections of the running track would be left in place from the duct installation works or be reinstated to allow access to more remote joint locations. It is estimated that a running track would be required for 20% of the total onshore cable route length for the cable pull and jointing works.
41. The development of the access strategy for this stage has been informed by a reduced demand for materials and employees (relative to stage 2) leading to a substantial reduction in forecast traffic demand.
42. A review of over 200 access tracks, public highway roads and running track crossing points (from the previous construction stage) has been undertaken taking into account potential joint pit locations. This has narrowed down the potential access points to the 75 locations as presented in this plan (refer to Table 1.3).

¹ Trenchless crossing techniques include HDD/Auger Bore/Micro Tunnel

1.5.4 Access Strategy Summary

43. Table 1.3 details all accesses (AC) required for stage 2 (duct installation works and onshore project substation primary works) and stage 3 (cable pull, joint and commission) construction phases. Locations for ACs are detailed graphically in the DCO Access to Work Plans (document reference 2.5).
44. For stage 2, the project components to be accessed are detailed as follows: MA (mobilisation area), TC (trenchless crossing location), landfall and onshore project substation. For stage 3, the section of the onshore cable route to be accessed is detailed.

Table 1.3 Access location and function

Access ID	Highway Link	Potential Access Route	Stage 2	Stage 3
AC3	Whimpwell Street	B1159, Vicarage Road, The Common, Coronation Road, Whimpwell Street	Landfall	Cable Section 16
AC5	Grub Street	B1159, N Walsham Road, Grub Street	Crossing only	Cable Section 16
AC10	Walcott Green	B1159, N Walsham Road, Walcott Green	Crossing only	Cable Section 16
AC12	North Walsham Road	B1159, North Walsham Road	Not required	Cable Section 16
AC13	North Walsham Road	B1159, North Walsham Road	MA11 (Cable section 17 & 18)	Cable Section 15 & 16
AC16	North Walsham Road	B1159, Happisburgh Road, N Walsham Road	Crossing only	Cable Section 15
AC18	Hole House Road	B1159, Happisburgh Road, N Walsham Road, Hole House Road	Crossing only	Cable Section 15
AC20	Edingthorpe	B1159, N Walsham Road, Bacton Road, Edingthorpe	Not required	Cable Section 15
AC21	Bacton Road	B1159, Happisburgh Road, N Walsham Road, Bacton Road	Crossing only	Cable Section 15
AC22	Edingthorpe Road	B1159, Happisburgh Road, N Walsham Road, Bacton Road, Edingthorpe Road	Crossing only	Cable Section 15

Access ID	Highway Link	Potential Access Route	Stage 2	Stage 3
AC24	Edingthorpe	B1159, Bloodslat Lane, N Walsham Road, Plantation Road	TC16(e)	Cable Section 14
AC25	Plantation Road	B1159, Bloodslat Lane, N Walsham Road, Plantation Road	MA10a Cable Section 17a TC16(w).	Cable Section 14
AC28	North Walsham Road	B1159, Bloodslat Lane, N Walsham Road	Crossing only	Cable Section 14
AC32	Paston Road	B1159, Bloodslat Lane, N Walsham Road, Paston Road	Crossing only	Cable Section 14
AC34	Hall Lane	B1145, Bacton Road, Hall Lane	TC15(e)	Cable Section 14
AC35	Hall Lane	B1159, Bloodslat Lane, N Walsham Road, Hall Lane	TC15(e)	Cable Section 14
AC37	Little London Road	B1145, Little London Road	TC14(e), TC15(w)	Cable Section 14
AC38	B1145	B1145	MA10 (Cable Section 15 & 16a) TC13(e)	Cable Section 14
AC47	A149	A149	MA9 (Cable section 14) TC12(e)(w), TC13(w)	Cable Section 13
AC49	Felmingham Road	B1145, Felmingham Road	Crossing only	Cable Section 13
AC50	Felmingham Road	B1145, Felmingham Road	Not required	Cable Section 13
AC51	Brick Kiln Lane	B1145, Felmingham Road, Brick Kiln Lane	Not required	Cable Section 13
AC55	Suffield Road	B1145, Suffield Road	TC11(e)	Cable Section 12
AC57	Church Road, into farm	A140, High Noon Road, Church Road	TC11(w)	Cable Section 12

Access ID	Highway Link	Potential Access Route	Stage 2	Stage 3
	access			
AC58	Church Road	A140, High Noon Road, Church Road	Crossing only	Cable Section 12
AC62	Banningham Road	A140, Banningham Road	Crossing only	Cable Section 11
AC66	A140	A140	MA8 (Cable section 13) TC10(w)(e), TC9(w)	Cable Section 11
AC75	Un-named Road	B1149, B1354 (Brickling Road), Un-named Road	TC9(w)	Cable Section 11
AC77	Blickling Road	B1149, B1354 (Brickling Road)	Crossing only	Cable Section 10 & 11
AC78	Blickling Road	B1149, B1354 (Brickling Road)	Not required	Cable Section 10
AC84	Heydon Road	B1149, The Street, Heydon Road	MA7 (Cable section 11 & 12)	Cable Section 10
AC85	Heydon Road	B1149, The Street, Heydon Road	Not required	Cable Section 10
AC88	The Street	B1149, The Street	Not required	Cable Section 9
AC89	B1149	B1149	Crossing only	Cable Section 9
AC91	Southgate (Road to Southgate from B1149)	B1149, Southgate	Not required	Cable Section 9
AC92	Southgate (Road to Southgate from B1149)	B1149, Southgate	Crossing only	Cable Section 9
AC96	Heydon Road	B1149, B1145, Heydon Road	Crossing only	Cable Section 9
AC102	B1145 (Cawston)	B1149, B1145	MA7 (Cable section 9 & 10)	Cable Section 8
AC103	B1145 (Cawston)	B1149, B1145	TC8(e)	Cable Section 8

Access ID	Highway Link	Potential Access Route	Stage 2	Stage 3
AC105	B1145 (Reepham)	B1145	Cable section 9a TC7(e), TC8(w)	Cable Section 8
AC107	Wood Dalling Road	B1145, Wood Dalling Road	Crossing only	Cable Section 8
AC108	Worlds End Lane	B1149, B1145, Wood Dalling Road, Worlds End Lane	Not required	Cable Section 8
AC110	B1145 (Bawdeswell)	A1067	Cable section 8a TC7(w)	Cable Section 7
AC111	B1145 (Bawdeswell)	A1067	Cable section 8a TC6(n)	Cable Section 7
AC112	B1145 (Bawdeswell)	A1067	TC6(s)	Cable Section 7
AC121	Private Access Track (Adjacent to Well Lane)	A1067, B1145, Private Access Track (Adjacent to Well Lane)	MA 5b (Cable section 8)	Cable Section 6
AC122	Lime Kiln Road	A1067, Lime Kiln Road	MA 5a (Cable section 7)	Cable Section 6
AC126	Mill Street	A1067, Elsing Lane, Mill Street	Crossing only	Cable Section 5
AC127	Unnamed Road to Bylaugh Hall	A1067, Elsing Lane, Unnamed Road to Bylaugh Hall	Cable section 16a TC5(e)	Cable Section 5
AC128	Elsing Road	A1067, B1147, Elsing Road	Not required	Cable Section 5
AC131	Elsing Road	A1067, B1147, Elsing Road	TC5(w)	Cable Section 5
AC132	Elsing Road, Private Access Track	A1067, B1147, Elsing Road, Private Access Track	Not required	Cable Section 5
SA135	Mowles Road, Farm Access Track	A47, B1147 (Norwich Road), Mowles Road, Farm Access Track	Not required	Cable Section 4

Access ID	Highway Link	Potential Access Route	Stage 2	Stage 3
AC136	Norwich Road	A47, B1147 (Norwich Road), Mowles Road, Norwich Road	Crossing only	Cable Section 4
AC137	Luddenham Road	A47, B1147 (Norwich Road), Mowles Road, Luddenham Road	MA4 (Cable section 5 & 6)	Cable Section 4
AC138	Swanton Road	A47, B1147 (Norwich Road), Mowles Road, Luddenham Road, Swanton Road	Crossing only	Cable Section 4
AC142	Hoe Road South	A47, B1147 (Norwich Road), Mowles Road, Luddenham Road, Swanton Road, Hoe Road South	Not required	Cable Section 4
AC143	Hoe Road South	A47, B1147 (Norwich Road), Mowles Road, Luddenham Road, Swanton Road, Hoe Road South	Not required	Cable Section 4
AC144	Hoe Road South	A47, B1147 (Norwich Road), Mowles Road, Luddenham Road, Swanton Road, Hoe Road South	TC4(w)(e)	Cable Section 4
AC145	Back Lane	A1067, B1145, B1110	Crossing only	Cable Section 4
AC147	B1146 (Holt Road)	A1067, B1145, B1110	MA4 (Cable section 3 & 4)	Cable Section 3
AC148	B1146 (Holt Road)	A1067, B1145, B1110	Not required	Cable Section 3
AC151	Mill Lane	A1067, B1146, Gressenhall Road to Dillington	TC3b(e)	Cable Section 3
AC152	Church Lane	A1067, B1146, Gressenhall Road to Dillington, Church Lane	TC3b(w)	Cable Section 3
AC153	Church Lane	B1146, Rushmeadow Rd, Longham Rd	TC3a(w)	Cable Section 3
AC160	Unnamed Road	A47, Unnamed Road	MA2 (Cable Section 2) TC1(n), TC2(n)(s)	Cable Section 2
AC161	Dale Road	A47, Dale Road	TC1(s)	Cable Section 2
AC163	Dereham	A47, Greenbanks Road, Dereham Road	MA 1b (Cable	Cable Section 2

Access ID	Highway Link	Potential Access Route	Stage 2	Stage 3
	Road		section 1)	
AC164	Dale Road	A47, Greenbanks Road, Dereham Road, Dale Road	Crossing only	Cable Section 2
AC165	Dereham Road	A47, Greenbanks Road	Crossing only	Cable Section 2
AC166	Bradenham Lane	A47, Bradenham Lane	Not required	Cable Section 2
AC167	Bradenham Lane	A47, Bradenham Lane	Not required	Cable Section 1
AC181	A47	A47	National Grid Substation Extension	Not required
AC182	A47	A47	National Grid Overhead Line Modifications	Not required
AC183	A47	A47	MA1a (Cable section 0 & 1) Onshore project substation	Cable Section 1

1.6 Access Design

1.6.1 General Approach

45. The OAMP presents access design principles and concepts to be developed by the appointed contractor.
46. The recommendations contained within this document will be subject to detailed engineering and assessment of traffic management requirements in consultation with the relevant authorities (NCC and HE). All designs will be subject to an independent road safety audit.
47. This process will ultimately determine the design requirement at each of the project access points referred to in Table 1.3, including visibility requirements, adoption of any temporary speed reductions or other traffic management measures and any agreed departures from DMRB standards.

48. In addition to the powers set out in the draft DCO, relevant powers under the Highways Act (1980), the Road Traffic Regulation Act (1984) and the New Roads and Street Works Act (1991) may also be relied upon to implement the access strategy (e.g. to implement temporary speed limits).
49. The relevant drainage authorities would be consulted when determining appropriate access treatment to cross a water course.
50. The onshore project substation requires specific design considerations as the location will be subject to high traffic demand during the construction phase of the project and will be a permanent component to serve the operational phase of the project.
51. Appendix 1 contains a technical note on onshore project substation permanent access, which examines the options available and has been developed in consultation with Highways England. The note examines the safety, environmental and infrastructure implications of various access options and concluded that three options (or a combination of options) are equally viable for access off the A47(T):
 - Utilising the existing Dudgeon substation access with restrictions on right-turn manoeuvres;
 - A standard¹ compliant junction at the existing Dudgeon substation access; and
 - A standard compliant junction at 'Spicers Corner' east of the existing Dudgeon substation access.
52. The final preferred access choice would be determined in the discharge of Requirement 22 of the DCO in consultation with NCC and HE.
53. Apart from the onshore project substation, all other project access points are temporary and following completion of construction would be reinstated to their former state unless otherwise agreed with the relevant local authority.
54. The design process will be supported by a Stage 1 Road Safety Audit² of each location.

1.6.2 Design Considerations

55. Access to the onshore cable route has been developed assuming the use of a suitably sized HGV (a 20t payload tipper and a low loader). The design of the accesses will provide suitable radii/ overrun areas for these vehicle types.
56. To minimise overrun areas on minor roads, it is assumed the HGVs entering the side access will be able to use the entire width of the side access carriageway to manoeuvre (rather than adhere to lane discipline).

57. With the exception of a small number of locations, the majority of the local highway network operates a 60mph speed limit. Most of the roads are rural, single carriageway or tracks with no footways or street lighting present; many with established hedgerows or trees forming the highway boundary.
58. The Design Manual for Roads and Bridges (DMRB) is adopted as the most appropriate design standard for major roads (A&B) and for visibility splays for all roads.
59. Minor road access design has been developed by means of 'first principles' i.e. using vehicle simulation tools to size the side access.
60. The guiding principle in developing the access designs is to minimise the impact on the surrounding environment. Recognising the temporary nature of the majority of the accesses, opportunities will be sought to 'step below' design standards to minimise impact whilst maintaining safety.
61. If a requisite visibility splay cannot be achieved without substantial hedgerow removal, in the first instance the designer will seek to introduce speed limits/traffic management to reduce the distance required.

1.6.3 Access Design Concepts

62. Four access design concepts have been developed for the project as shown in Appendix 2:
 - Type A access: a fully standard compliant (DMRB) major/ minor road junction (as shown in RHDHV drawing PB4476-DR-H1-D-0100). Intended for use on A and major B roads. For this type of access, the requirement for a major road right turn lane would be determined in accordance with validated turning traffic demand;
 - Type B and C access: a reduced footprint access suitable for small B roads, minor and unclassified roads (as shown in RHDHV drawing PB4476-DR-H1-D-0101); and
 - Type D access: a running track crossing point. This type of access could be adapted for limited construction traffic demand by adding radii to provide access where required to create a suitable access type A, B or C (as shown in RHDHV drawing PB4476-DR-H1-D-102).
63. Traffic control for each access type will be determined according to background traffic flow and visibility and would range from a simple priority junction to traffic signal control. For roads with high traffic flows a 'staggered' arrangement would be considered, incorporating type A access.

64. In all cases advance hazard warning signs will be provided in accordance with the Traffic Signs Manual, Chapter 8, Traffic Safety Measures and Signs for Road Works and Temporary Solutions, Parts 1 and 2, commonly referred to as Chapter 8. This signage will encourage drivers to slow in the knowledge that there is a hazard ahead such as the potential for turning vehicles.
65. The required public highway crossings and side accesses have been reviewed to determine appropriate access type and the requirement for traffic management to secure a suitable visibility splay. The results are set out in Table 1.4.

Table 1.4 Access review

Access ID	Stage 2 Access Type Required	Stage 2 - Main Duct Installation Stage Peak HGVs Movements (AADT)	Stage 3 Access Type Required	Stage 3 - Cable Pull Stage Peak HGVs Movements (AADT)	Existing speed limit (mph)	Visibility compliance* for existing design speed (Y/N)	Temp speed reduction required (Y/N)
AC3	D/B or C	61	B or C	31	30	Y	N
AC5	D	-	B or C	31	60	N	Y
AC10	D	-	B or C	31	60	N	Y
AC12	-	-	B or C	31	60	N	Y
AC13	B or C	96	B or C	31	60	N	Y
AC16	D	-	B or C	31	30	Y	N
AC18	D	-	B or C	32	60	N	Y
AC20	-	-	B or C	32	60	N	Y (East only)
AC21	D	-	B or C	32	60	Y	Y
AC22	D	-	B or C	32	60	N	Y
AC24	B or C	72	B or C	38	60	N	Y
AC25	B or C	72	B or C	30	60	N	Y

Access ID	Stage 2 Access Type Required	Stage 2 - Main Duct Installation Stage Peak HGVs Movements (AADT)	Stage 3 Access Type Required	Stage 3 - Cable Pull Stage Peak HGVs Movements (AADT)	Existing speed limit (mph)	Visibility compliance* for existing design speed (Y/N)	Temp speed reduction required (Y/N)
AC28	D	-	B or C	30	60	N	Y
AC32	D	-	B or C	30	60	N	Y
AC34	B or C	72	B or C	30	60	N	Y
AC35	D/B or C	72	B or C	30	60	N	Y
AC37	B or C	48	B or C	30	60	N	Y
AC38	A	120	B or C	30	30	Y	N
AC47	A	120	B or C	30	60	Y	N
AC49	D	-	B or C	36	60	N	Y
AC50	-	-	B or C	36	60	Y	N
AC51	-	-	B or C	36	60	Y	N
AC55	D/B or C	72	B or C	31	60	N	Y
AC57	B or C	72	B or C	31	60	N	Y
AC58	D	-	B or C	31	60	N	Y

Access ID	Stage 2 Access Type Required	Stage 2 - Main Duct Installation Stage Peak HGVs Movements (AADT)	Stage 3 Access Type Required	Stage 3 - Cable Pull Stage Peak HGVs Movements (AADT)	Existing speed limit (mph)	Visibility compliance* for existing design speed (Y/N)	Temp speed reduction required (Y/N)
AC62	D	-	B or C	31	60	N	Y
AC66	A	144	B or C	33	60	Y	N
AC75	B or C	72	B or C	36	60	Y	N
AC77	D	-	B or C	35	60	N	Y
AC78	-	-	B or C	31	60	N	Y
AC84	D/B or C	96	B or C	35	60	N	Y
AC85	-	-	B or C	35	60	Y	N
AC88	-	-	B or C	35	60	Y	N
AC89	D	-	A	29	60	Y	N
AC91	-	-	B or C	29	60	N	Y
AC92	D	-	B or C	29	60	N	Y
AC96	D	-	B or C	29	60	N	N
AC102	D/A	96	A	31	60	Y	N

Access ID	Stage 2 Access Type Required	Stage 2 - Main Duct Installation Stage Peak HGVs Movements (AADT)	Stage 3 Access Type Required	Stage 3 - Cable Pull Stage Peak HGVs Movements (AADT)	Existing speed limit (mph)	Visibility compliance* for existing design speed (Y/N)	Temp speed reduction required (Y/N)
AC103	A	72	A	31	60	N	Y
AC105	D/A	120	A	31	60	N	Y
AC107	D	-	B or C	31	60	N	Y
AC108	-	-	B or C	31	60 N/ 30 S	N (North only)	Y (North only)
AC110	B or C	72	B or C	38	60	N	Y
AC111	B or C	72	B or C	38	60	N	Y
AC112	B or C	72	B or C	38	60	N	Y
AC121	A	48	A	33	60	Y	N
AC122	B or C	48	B or C	33	60	N	Y
AC126	D	-	B or C	30	60	N	Y
AC127	B or C	72	B or C	30	60	N	Y
AC128	D/B or C	-	B or C	30	60	N	Y
AC131	B or C	72	B or C	30	60	Y	N

Access ID	Stage 2 Access Type Required	Stage 2 - Main Duct Installation Stage Peak HGVs Movements (AADT)	Stage 3 Access Type Required	Stage 3 - Cable Pull Stage Peak HGVs Movements (AADT)	Existing speed limit (mph)	Visibility compliance* for existing design speed (Y/N)	Temp speed reduction required (Y/N)
AC132	-	-	B or C	30	60	N	Y
AC135	-	-	B or C	29	60	N	Y
AC136	D	-	B or C	29	60	N	Y
AC137	D/A	96	B or C	29	60	N	Y
AC138	D	-	B or C	29	30 N/ 60 S	Y (North)/ N (South)	Y (South only)
AC142	-	-	B or C	29	60	N	Y
AC143	-	-	B or C	29	60	N	Y
AC144	B or C	96	B or C	29	60	N	Y
AC145	D	-	B or C	29	60	Y	N
AC147	D/A	96	B or C	34	60	N	Y
AC148	-	-	B or C	34	60	N (South only)	Y (South only)
AC151	B or C	72	B or C	34	60	N	Y
AC152	B or C	72	B or C	34	60	N	Y

Access ID	Stage 2 Access Type Required	Stage 2 - Main Duct Installation Stage Peak HGVs Movements (AADT)	Stage 3 Access Type Required	Stage 3 - Cable Pull Stage Peak HGVs Movements (AADT)	Existing speed limit (mph)	Visibility compliance* for existing design speed (Y/N)	Temp speed reduction required (Y/N)
AC153	D/B or C	72	B or C	34	60	N	Y
AC160	B or C	144	B or C	34	60	N	Y
AC161	B or C	72	B or C	34	60	N	Y
AC163	A	48	A	34	60	Y	N
AC164	D	-	B or C	34	60	N	Y
AC165	D	-	B or C	34	60	N	Y
AC166	-	-	B or C	34	60	N	Y
AC167	-	-	B or C	33	60	N	Y
AC181	Existing	68	-	-	60	Y	N
AC182	B or C	tbc	-	-	60	Y	N
AC183	A - Permanent	150	A - Permanent	33	60	Y	N
*	DMRB visibility compliance in accordance to the DMRB TD 42/95 Volume 6 Section 2 Part 6 – Table 7/1						

66. Finalised drawings, showing full details of access improvements and hierarchical strategies allowing safe access/egress from the highway onto the onshore cable route would be agreed as part of the development of the AMP (once a contractor has been appointed), and in consultation with NCC and HE.

1.7 References

Design Manual for Roads and Bridges, Vol 6, Section 2, Part 6, TD 42/95 'Geometric Design of Major/Minor Priority Junctions'.

Design Manual for Roads and Bridges, Vol 5, Section 2, Part 2, HD 19/15 'Road Safety Audit'.

Traffic Signs Manual, Chapter 8, 'Traffic safety measures and Signs for Road Works and Temporary solutions, Parts 1 and 2'

1.8 Figures

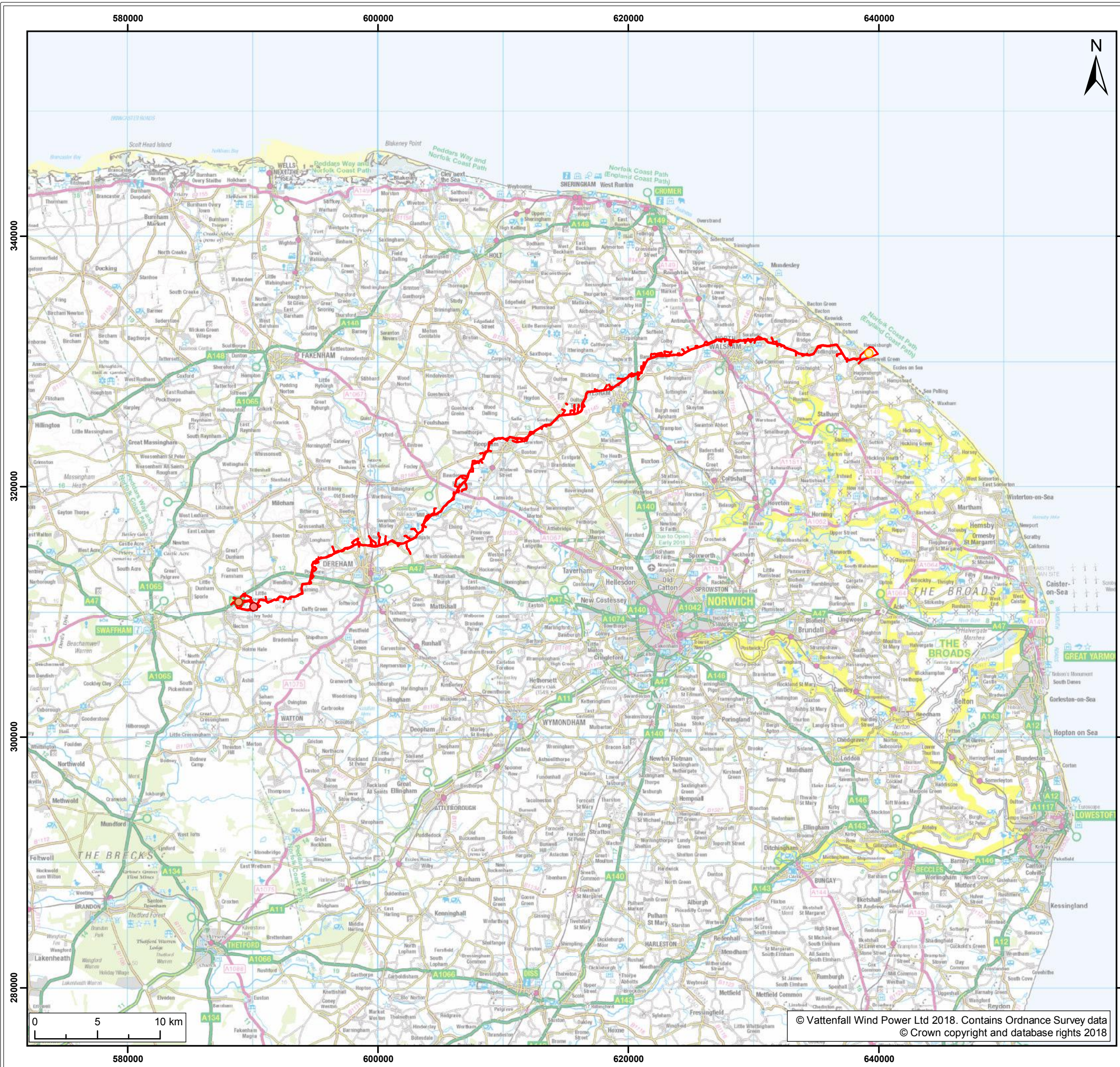

- Legend:
- Norfolk Vanguard onshore red line boundary
 - Landfall zone location
 - Onshore project substation location
 - National Grid substation extension location

Project: Norfolk Vanguard	Report: Outline Access Management Plan
------------------------------	---

Title:
Cable Route (Study Area)

Figure: 1	Drawing No: PB4476-006-008-001				
Revision:	Date:	Drawn:	Checked:	Size:	Scale:
02	28/01/2019	LB	RE	A3	1:300,000
01	02/05/2018	LB	RE	A3	1:300,000

Co-ordinate system: British National Grid EPSG: 27700



© Vattenfall Wind Power Ltd 2018. Contains Ordnance Survey data
© Crown copyright and database rights 2018

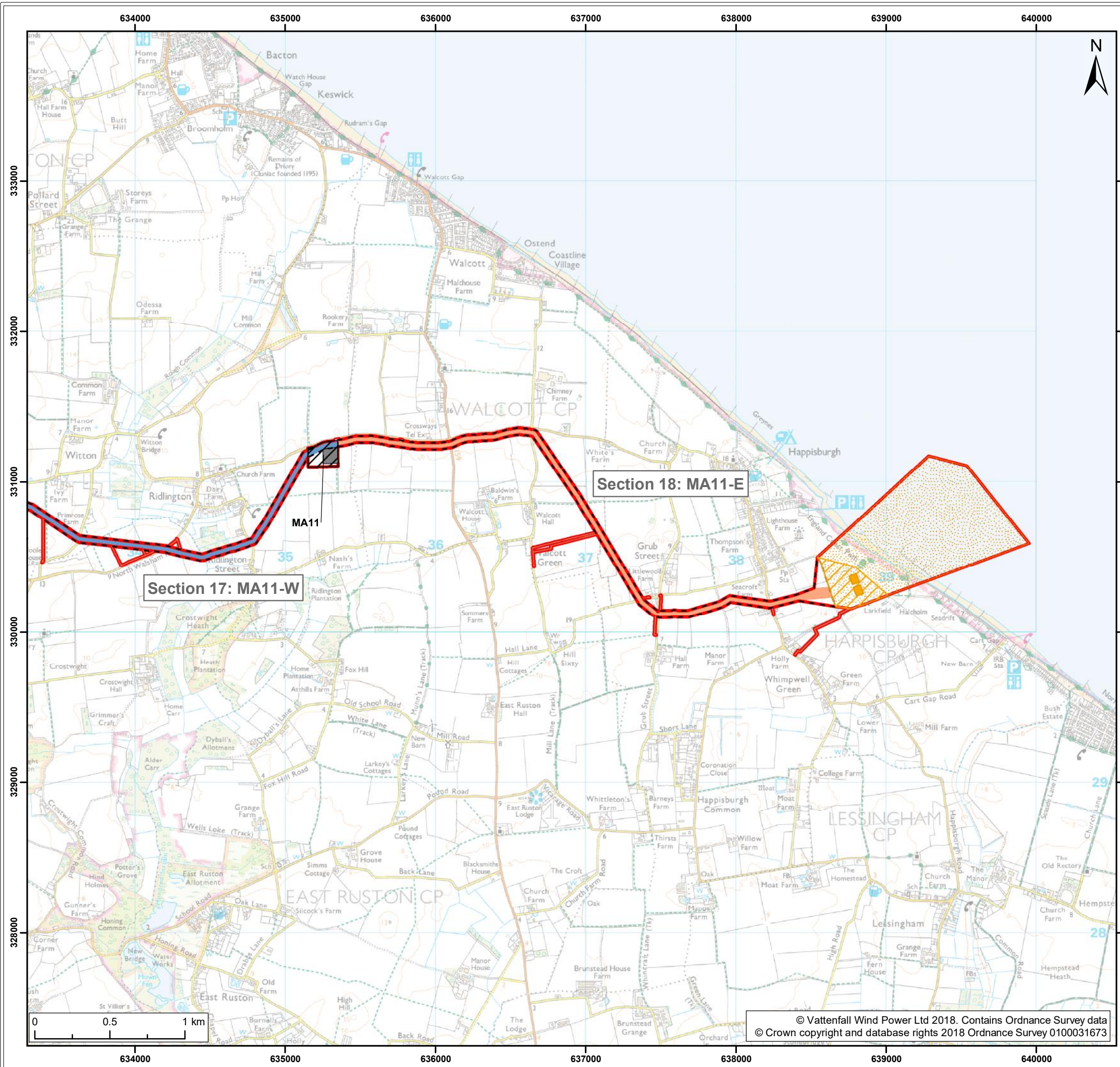

Legend:

- Norfolk Vanguard onshore red line boundary
- Landfall**
- Landfall zone
- Landfall compound zone
- Indicative landfall compound
- Onshore cable route**
- Onshore cable route
- Mobilisation zone
- Indicative mobilisation area compound
- Access**
- Construction access
- Operation access
- Cable Route Sections**
- Section 17: MA11-W
- Section 18: MA11-E

MA = Mobilisation Area

Project: Norfolk Vanguard	Report: Outline Access Management Plan
-------------------------------------	--

Title:
Onshore Cable Route Project Components (map 1 of 9)

Figure: 2	Drawing No: PB4476-006-008-002				
Revision:	Date:	Drawn:	Checked:	Size:	Scale:
03	24/01/2019	JT	RE	A3	1:25,000
02	08/06/2018	LB	RE	A3	1:25,000

Co-ordinate system: British National Grid EPSG: 27700

VATTENFALL

Royal HaskoningDHV
Enhancing Society Together

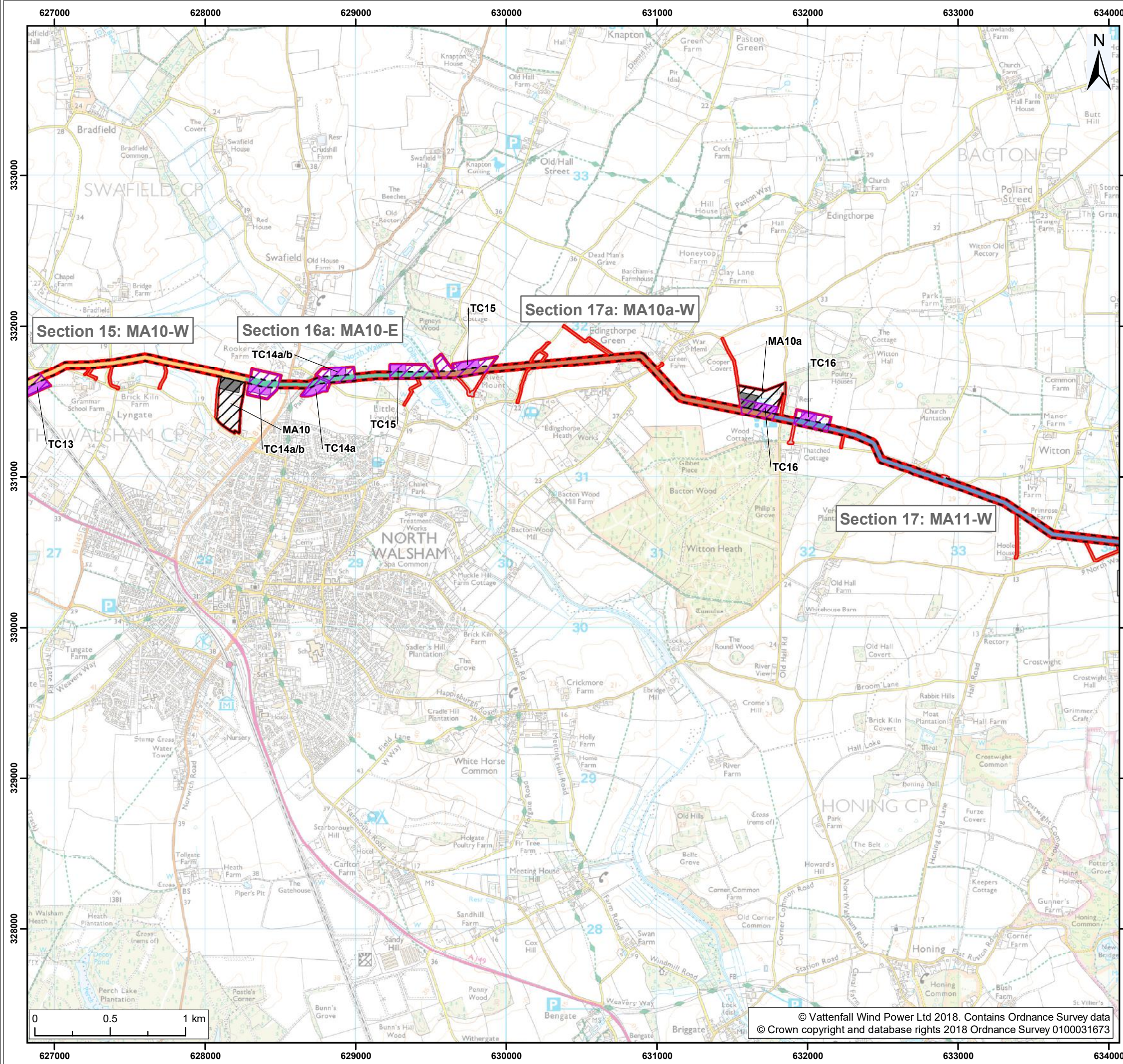

- Legend:**
- Norfolk Vanguard onshore red line boundary
 - Onshore cable route**
 - Onshore cable route
 - Trenchless crossing zone (e.g. HDD)
 - Indicative trenchless crossing compound
 - Mobilisation zone
 - Indicative mobilisation area compound
 - Access**
 - Construction access
 - Operation access
 - Cable Route Sections**
 - Section 15: MA10-W
 - Section 16a: MA10-E
 - Section 17: MA11-W
 - Section 17a: MA10a-W

MA = Mobilisation Area	
Project: Norfolk Vanguard	Report: Outline Access Management Plan

Title:
Onshore Cable Route Project Components
(map 2 of 9)

Figure: 2	Drawing No: PB4476-006-008-002				
Revision:	Date:	Drawn:	Checked:	Size:	Scale:
03	24/01/2019	JT	RE	A3	1:25,000
02	08/06/2018	LB	RE	A3	1:25,000

Co-ordinate system: British National Grid EPSG: 27700



© Vattenfall Wind Power Ltd 2018. Contains Ordnance Survey data
© Crown copyright and database rights 2018 Ordnance Survey 0100031673

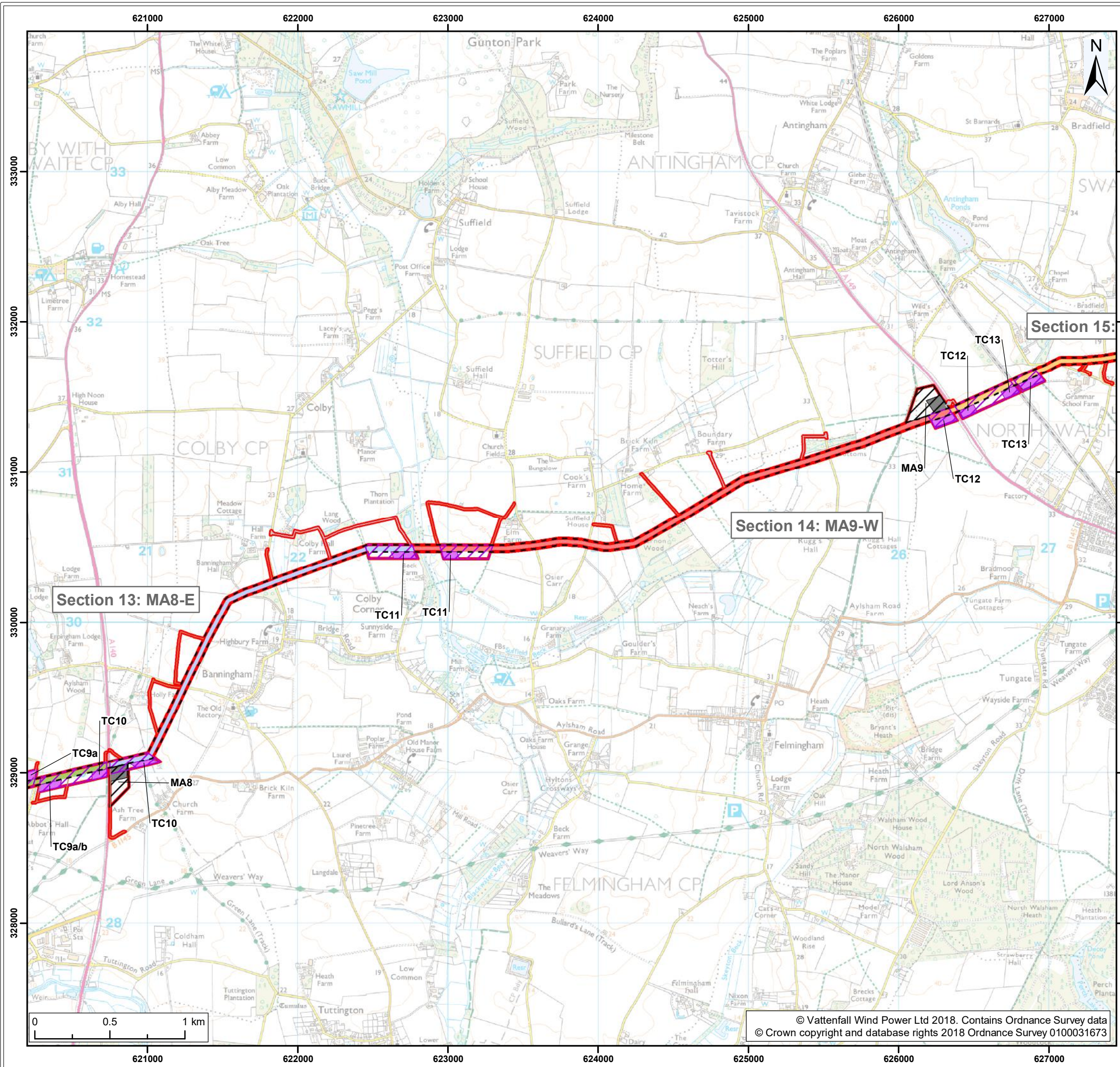

- Legend:
- Norfolk Vanguard onshore red line boundary
 - Onshore cable route**
 - Onshore cable route
 - Trenchless crossing zone (e.g. HDD)
 - Indicative trenchless crossing compound
 - Mobilisation zone
 - Indicative mobilisation area compound
 - Access**
 - Construction access
 - Operation access
 - Cable Route Sections**
 - Section 12: MA7-E
 - Section 13: MA8-E
 - Section 14: MA9-W
 - Section 15: MA10-W

MA = Mobilisation Area

Project: Norfolk Vanguard	Report: Outline Access Management Plan
------------------------------	---

Title:
Onshore Cable Route Project Components
(map 3 of 9)

Figure: 2	Drawing No: PB4476-006-008-002				
Revision:	Date:	Drawn:	Checked:	Size:	Scale:
03	24/01/2019	JT	RE	A3	1:25,000
02	08/06/2018	LB	RE	A3	1:25,000

Co-ordinate system: British National Grid EPSG: 27700



© Vattenfall Wind Power Ltd 2018. Contains Ordnance Survey data
© Crown copyright and database rights 2018 Ordnance Survey 0100031673

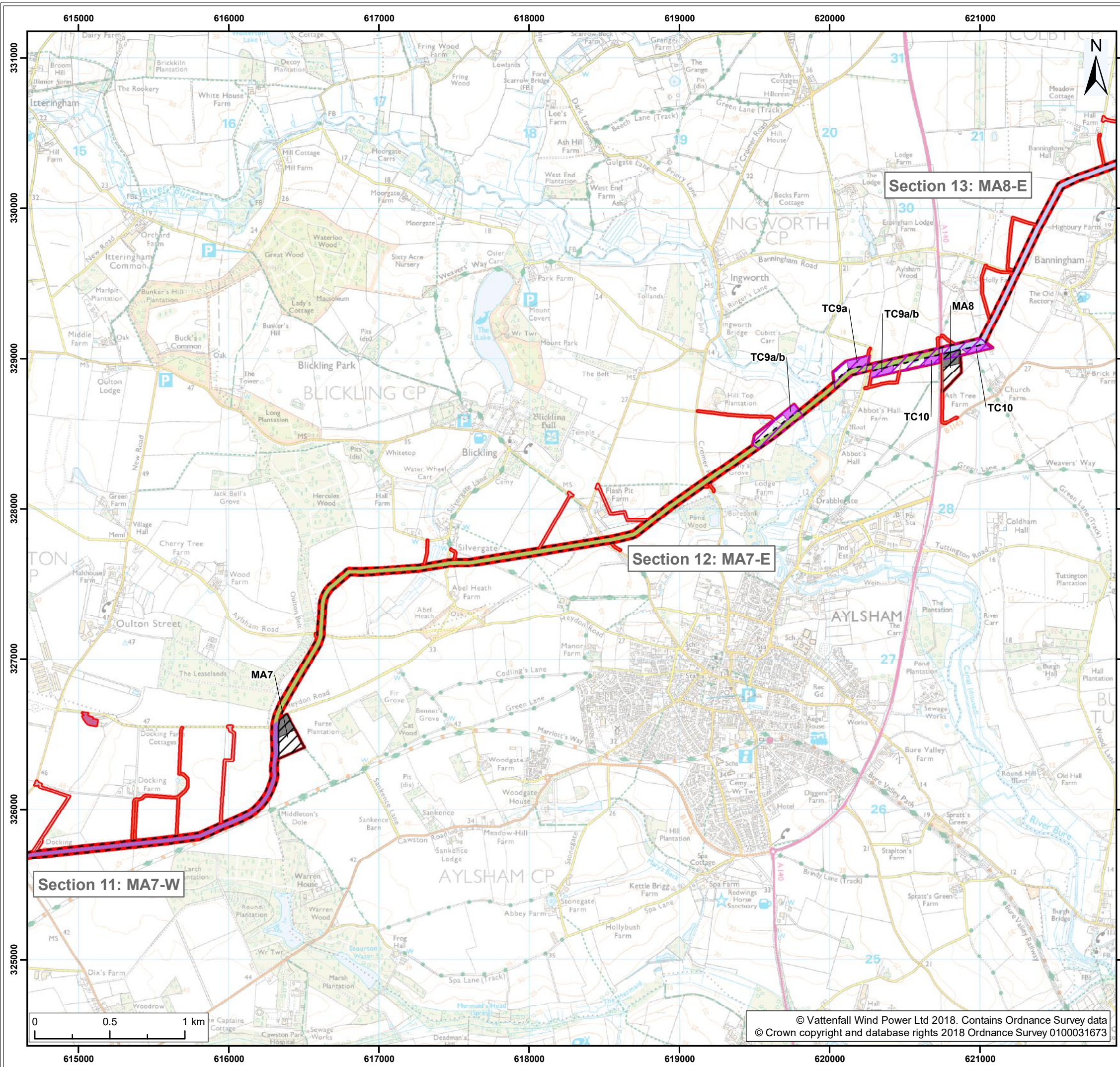

- Legend:**
- Norfolk Vanguard onshore red line boundary
 - Onshore cable route**
 - Onshore cable route
 - Trenchless crossing zone (e.g. HDD)
 - Indicative trenchless crossing compound
 - Mobilisation zone
 - Indicative mobilisation area compound
 - Cable logistics area
 - Access**
 - Construction access
 - Operation access
 - Cable Route Sections**
 - Section 11: MA7-W
 - Section 12: MA7-E
 - Section 13: MA8-E

MA = Mobilisation Area	
Project: Norfolk Vanguard	Report: Outline Access Management Plan

Title:
Onshore Cable Route Project Components
(map 4 of 9)

Figure: 2	Drawing No: PB4476-006-008-002				
Revision:	Date:	Drawn:	Checked:	Size:	Scale:
03	24/01/2019	JT	RE	A3	1:25,000
02	08/06/2018	LB	RE	A3	1:25,000

Co-ordinate system: British National Grid EPSG: 27700



© Vattenfall Wind Power Ltd 2018. Contains Ordnance Survey data
© Crown copyright and database rights 2018 Ordnance Survey 0100031673

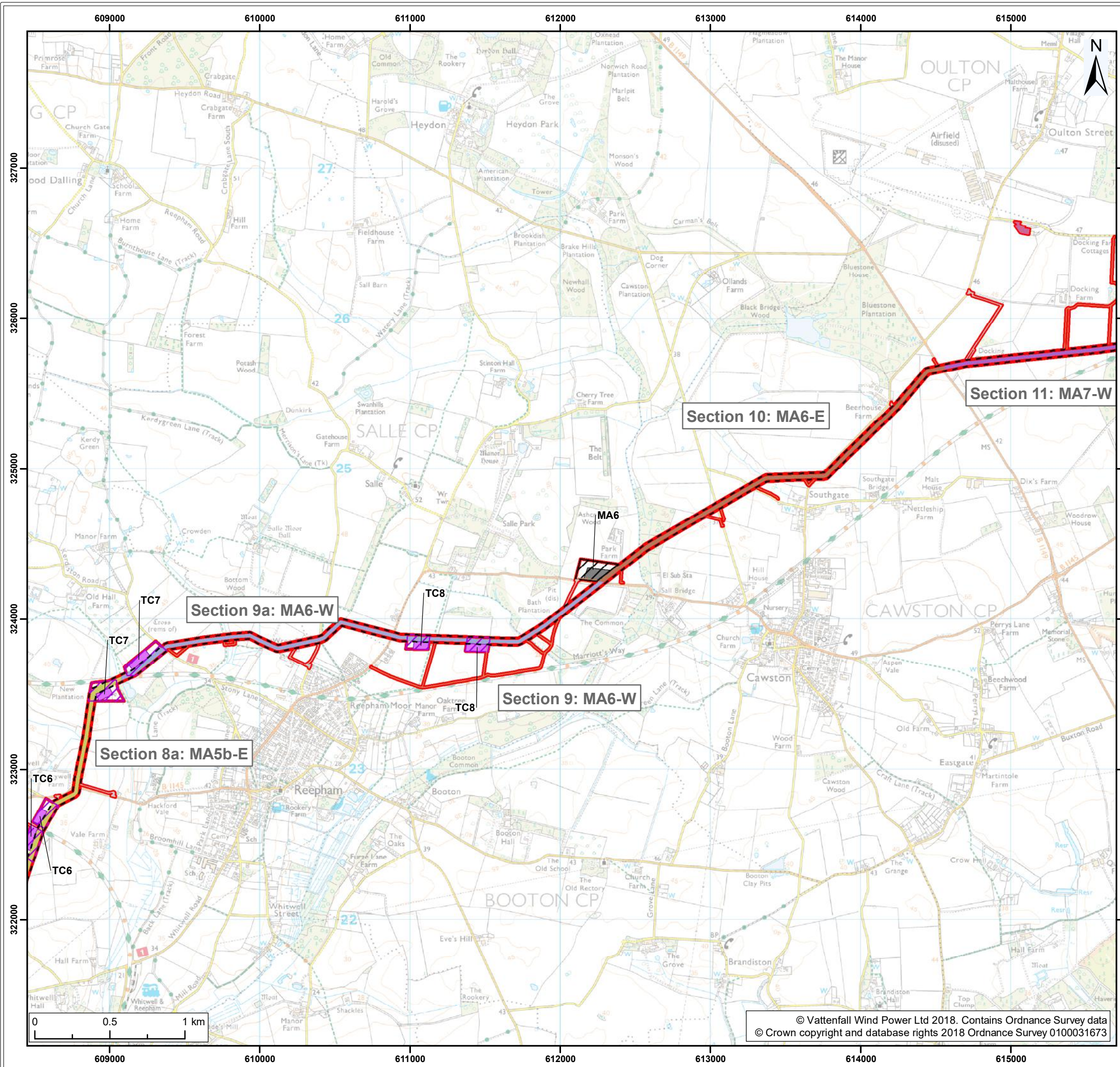

- Legend:
- Norfolk Vanguard onshore red line boundary
 - Onshore cable route**
 - Onshore cable route
 - Trenchless crossing zone (e.g. HDD)
 - Indicative trenchless crossing compound
 - Mobilisation zone
 - Indicative mobilisation area compound
 - Cable logistics area
 - Access**
 - Construction access
 - Operation access
 - Cable Route Sections**
 - Section 8a: MA5b-E
 - Section 9a: MA6-W
 - Section 10: MA6-E
 - Section 11: MA7-W

MA = Mobilisation Area	
Project: Norfolk Vanguard	Report: Outline Access Management Plan

Title:
Onshore Cable Route Project Components
(map 5 of 9)

Figure: 2	Drawing No: PB4476-006-008-002				
Revision:	Date:	Drawn:	Checked:	Size:	Scale:
03	24/01/2019	JT	RE	A3	1:25,000
02	08/06/2018	LB	RE	A3	1:25,000

Co-ordinate system: British National Grid EPSG: 27700



© Vattenfall Wind Power Ltd 2018. Contains Ordnance Survey data
© Crown copyright and database rights 2018 Ordnance Survey 0100031673

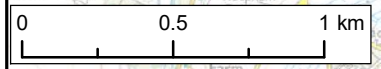

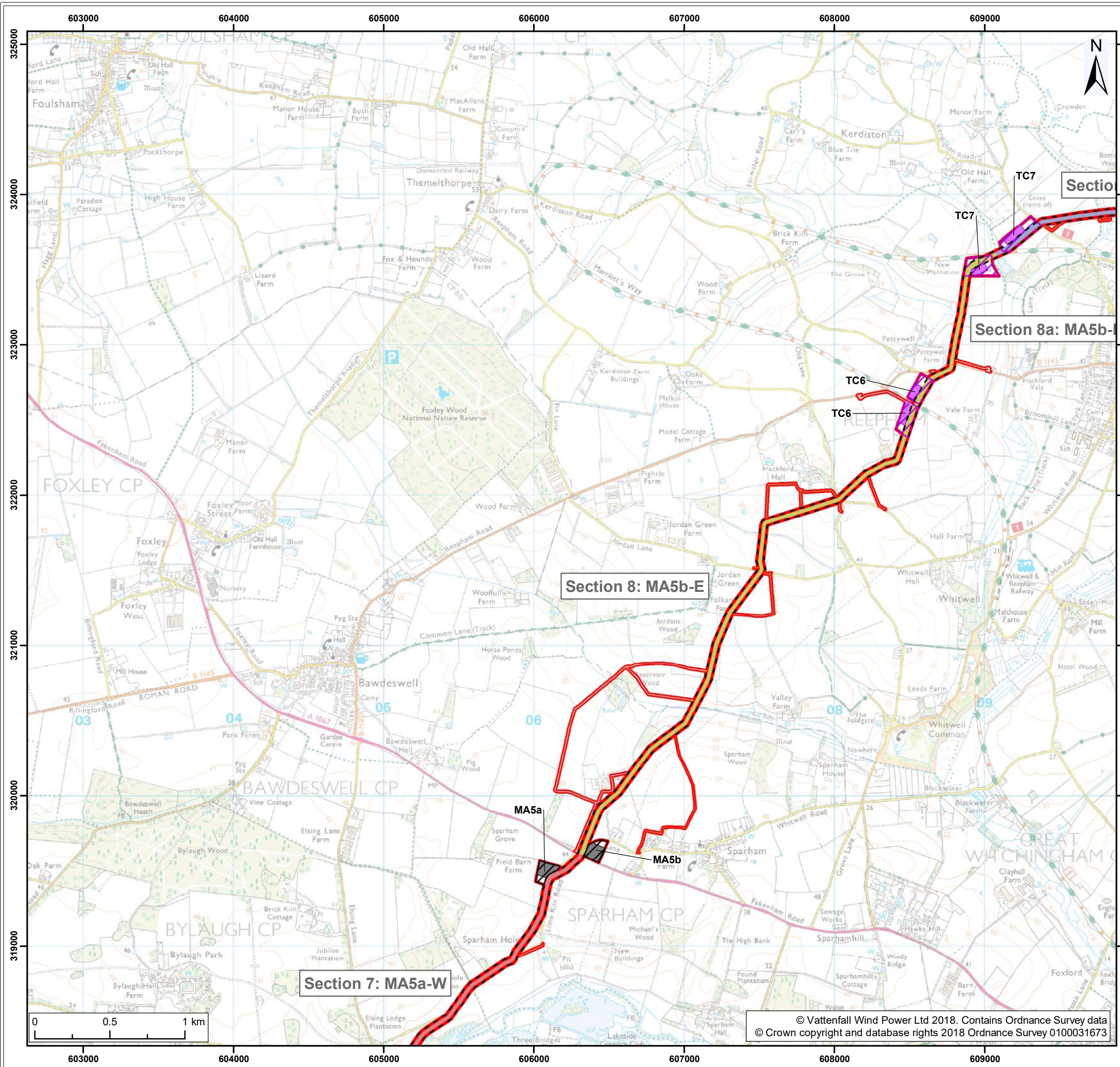

Legend:

- Norfolk Vanguard onshore red line boundary
- Onshore cable route**
- Onshore cable route
- Trenchless crossing zone (e.g. HDD)
- Indicative trenchless crossing compound
- Mobilisation zone
- Indicative mobilisation area compound
- Access**
- Construction access
- Operation access
- Cable Route Sections**
- Section 7: MA5a-W
- Section 8a: MA5b-E
- Section 9a: MA6-W

MA = Mobilisation Area

Project: Norfolk Vanguard	Report: Outline Access Management Plan
------------------------------	---

Title:
Onshore Cable Route Project Components
(map 6 of 9)

Figure: 2	Drawing No: PB4476-006-008-002				
Revision:	Date:	Drawn:	Checked:	Size:	Scale:
03	24/01/2019	JT	RE	A3	1:25,000
02	08/06/2018	LB	RE	A3	1:25,000

Co-ordinate system: British National Grid EPSG: 27700

VATTENFALL

Royal HaskoningDHV
Enhancing Society Together

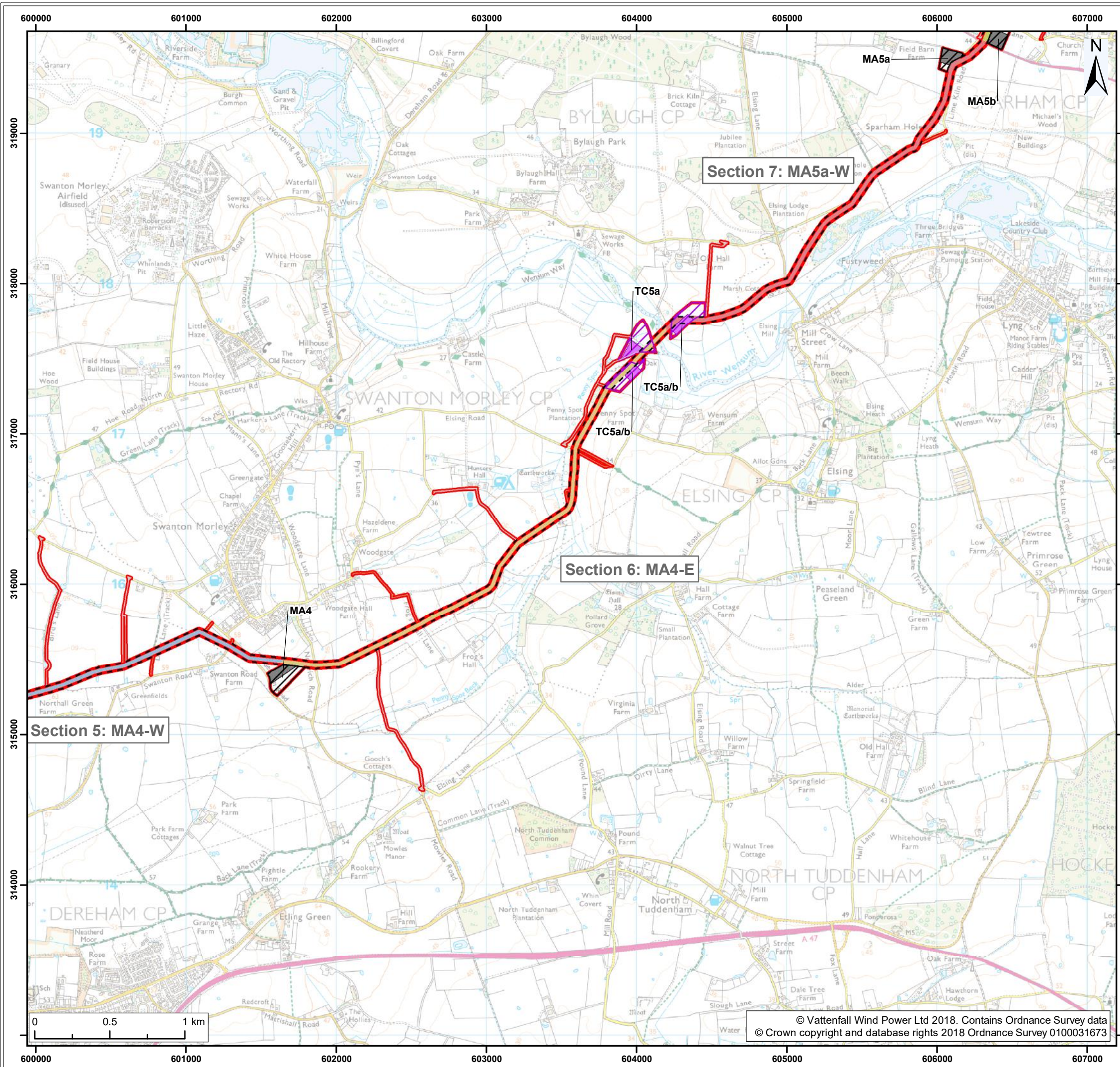

- Legend:**
- Norfolk Vanguard onshore red line boundary
 - Onshore cable route**
 - Onshore cable route
 - Trenchless crossing zone (e.g. HDD)
 - Indicative trenchless crossing compound
 - Mobilisation zone
 - Indicative mobilisation area compound
 - Access**
 - Construction access
 - Operation access
 - Cable Route Sections**
 - Section 5: MA4-W
 - Section 6: MA4-E
 - Section 7: MA5a-W
 - Section 8a: MA5b-E

MA = Mobilisation Area

Project:	Report:
Norfolk Vanguard	Outline Access Management Plan

Title:
Onshore Cable Route Project Components
(map 7 of 9)

Figure: 2	Drawing No: PB4476-006-008-002				
Revision:	Date:	Drawn:	Checked:	Size:	Scale:
03	24/01/2019	JT	RE	A3	1:25,000
02	08/06/2018	LB	RE	A3	1:25,000

Co-ordinate system: British National Grid EPSG: 27700



© Vattenfall Wind Power Ltd 2018. Contains Ordnance Survey data
© Crown copyright and database rights 2018 Ordnance Survey 0100031673

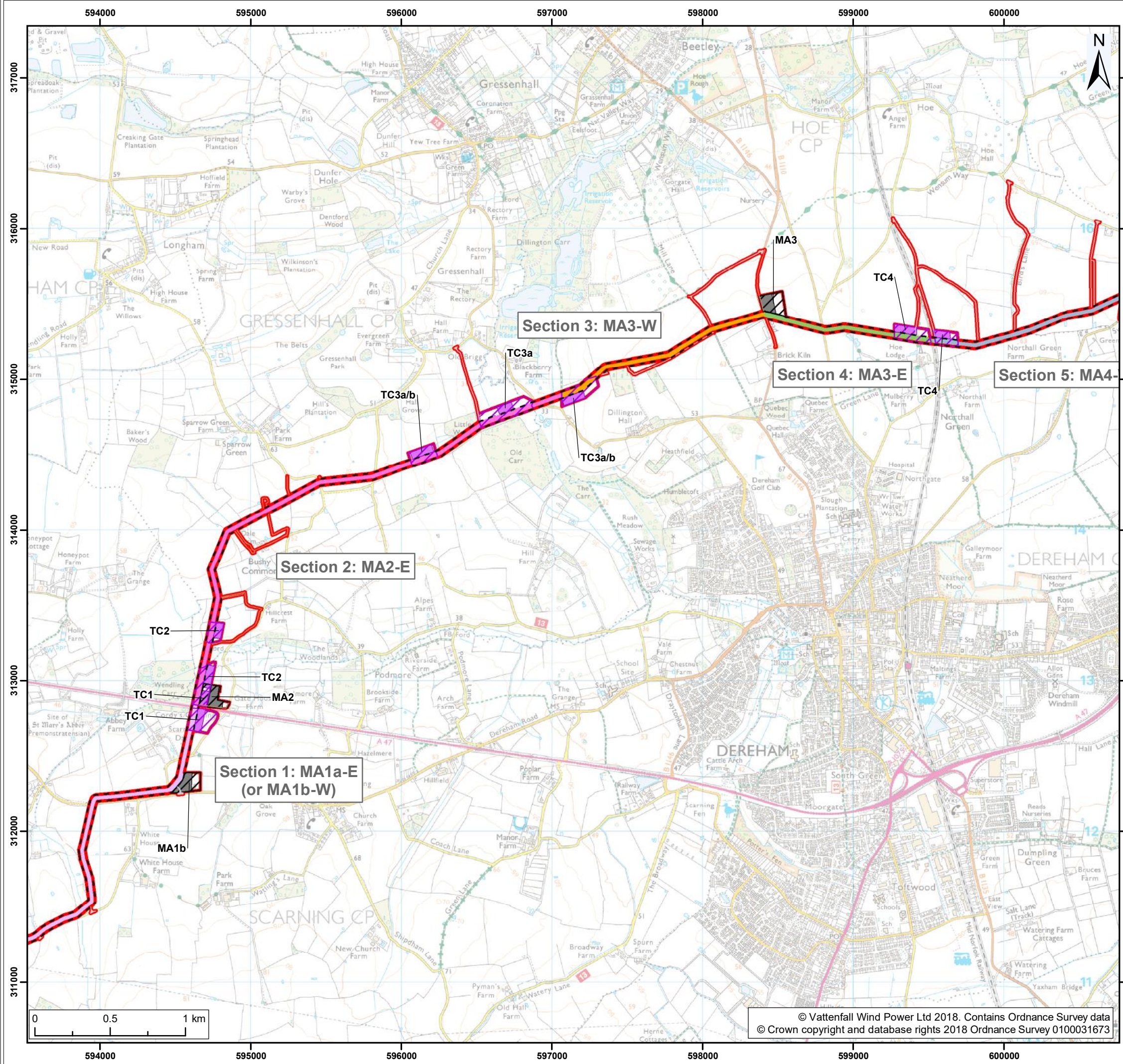

Legend:

- Norfolk Vanguard onshore red line boundary
- Onshore cable route**
- Onshore cable route
- Trenchless crossing zone (e.g. HDD)
- Indicative trenchless crossing compound
- Mobilisation zone
- Indicative mobilisation area compound
- Access**
- Construction access
- Operation access
- Cable Route Sections**
- Section 1: MA1a-E (or MA1b-W)
- Section 2: MA2-E
- Section 3: MA3-W
- Section 4: MA3-E
- Section 5: MA4-W

MA = Mobilisation Area

Project: Norfolk Vanguard	Report: Outline Access Management Plan
------------------------------	---

Title:
Onshore Cable Route Project Components
(map 8 of 9)

Figure: 2	Drawing No: PB4476-006-008-002				
Revision:	Date:	Drawn:	Checked:	Size:	Scale:
03	24/01/2019	JT	RE	A3	1:25,000
02	08/06/2018	LB	RE	A3	1:25,000

Co-ordinate system: British National Grid EPSG: 27700

VATTENFALL

Royal HaskoningDHV
Enhancing Society Together

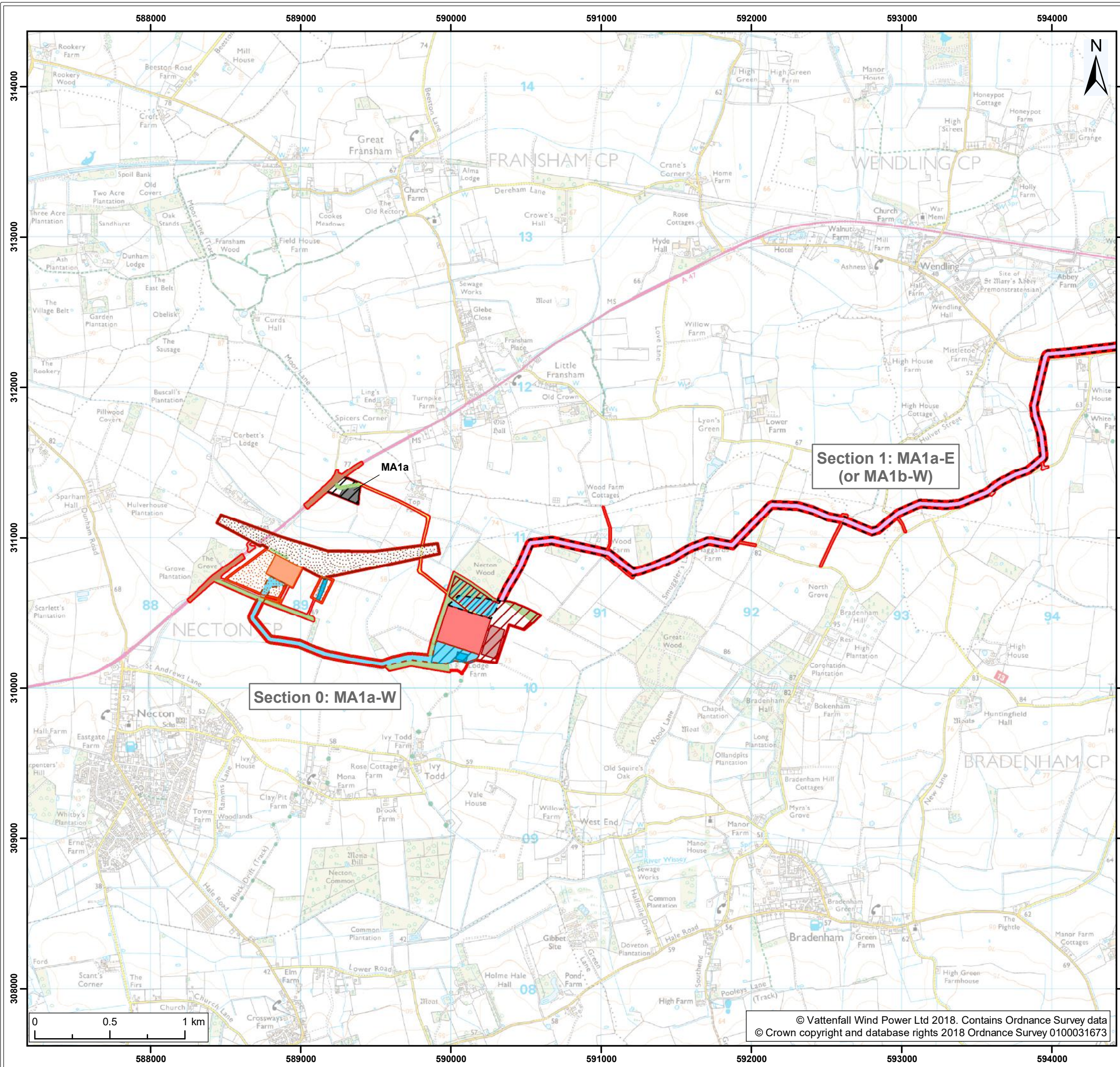

Legend:

- Norfolk Vanguard onshore red line boundary
- Onshore cable route
 - Onshore cable route
 - Onshore 400kv cable route
- Mobilisation zone
- Indicative mobilisation area compound
- Access**
 - Permanent access
 - Construction access
 - Operation access
- Onshore project substation**
 - Onshore project substation
 - Onshore project substation temporary construction compound zone
- Indicative onshore project substation temporary construction compound
- National Grid**
 - National Grid substation extension
 - National Grid temporary works
 - Overhead line temporary works
- Mitigation areas**
 - Attenuation pond zone
 - Indicative attenuation pond
 - Indicative mitigation planting
- Cable Route Sections**
 - Section 0: MA1a-W
 - Section 1: MA1a-E (or MA1b-W)

MA = Mobilisation Area

Project:	Report:
Norfolk Vanguard	Outline Access Management Plan

Title:
Onshore Cable Route Project Components (map 9 of 9)

Figure:	2	Drawing No:	PB4476-006-008-002			
Revision:	Date:	Drawn:	Checked:	Size:	Scale:	
03	24/01/2019	JT	RE	A3	1:25,000	
02	08/06/2018	LB	RE	A3	1:25,000	

Co-ordinate system: British National Grid EPSG: 27700

© Vattenfall Wind Power Ltd 2018. Contains Ordnance Survey data
© Crown copyright and database rights 2018 Ordnance Survey 0100031673

Appendix 1: A47 Access Technical Note

Note / Memo

**HaskoningDHV UK Ltd.
Transport & Planning**

To: Norfolk Vanguard Ltd
From: Royal HaskoningDHV
Date: 23 March 2018
Copy: Norfolk Vanguard Ltd
Our reference: T&PPB4476N002F2.0
Classification: Project related

Subject: Norfolk Vanguard Substation – A47 Substation Access Review

1 Introduction

This Technical Note (TN) has been prepared on behalf of Norfolk Vanguard Ltd in relation to the Norfolk Vanguard Offshore Windfarm Project ('the Norfolk Vanguard Project'). The note sets out a review of the Norfolk Vanguard Project onshore access options from the A47.

During the construction phase of the Norfolk Vanguard Project, Heavy Goods Vehicles (HGVs) and workforce traffic will require access to project infrastructure sites south of the A47, namely the:

- Onshore Project Substation;
- Mobilisation Area 1 (MA1); and
- National Grid Substation Extension (NGSE).

A subset of National Grid's construction traffic will need to access the field to the north of the A47 (where an electricity pylon is situated) to complete the Overhead Line Modification (OHLM) works.

Figure 01 details the project infrastructure sites and the associated access study area. The purpose of this note is to evaluate potential access options to inform the Norfolk Vanguard Project design.

1.1 Engagement

To facilitate stakeholder engagement a Transport Expert Topic Group (ETG) was established, consisting of transportation professionals from Norfolk County Council, Highways England and Norfolk Vanguard Ltd. The ETG raised a number of issues with respect to potential access off the A47 all of which have informed this technical note. **Table 1.1** details ETG and other relevant input.

Table 1.1: A47 Consultation Feedback

Consultee	Date	Comment
Highways England	27 February 2017: First Expert Topic Group Meeting	The proposed existing access off the A47 to substation site was presented. It was agreed that a review of the accident record would be undertaken if this facility was to be relied upon. Highways England explained that current policy does

		not prevent a new access from the A47 from being created, however, preference was for an existing access point to be utilised.
Highways England	7 March 2017: EIA Traffic & Transport Method Statement Response (Red:60506522/DN052.0002 BN01)	Impact on A47 at substation site near to Necton raised, requiring detailed analysis of traffic generation and a review of historic collisions.
Highways England and Norfolk county Council	17 July 2017: Second Expert Topic Group Meeting	Queries raised relating to the existing National Grid substation extension site access and potential for a new access north of the site. NCC noted a historic u-turn strategy at Dereham requiring HGV traffic to left turn into Substation Site.
Local Stakeholders	8 September 2017: Site visit with local stakeholders	Stakeholders voiced concerns in utilising a u-turn strategy at Dereham to negate the need for right turns into the substation site.
National Grid	Email correspondence	Liaison with National Grid to determine total quantity of vehicles required to access north of the A47.

2 Access Options

The accesses to be reviewed are detailed within **Table 2.1** together with the associated infrastructure sites served. The access locations are presented in **Figure 02**.

Table 2.1: Potential Accesses

Access ID	Access Description	Access to Infrastructure	Eastings	Northings
A	Existing Necton Electricity Substation access	NV onshore project substation NV MA1 NGSE	588435	310734
B	Existing Farm access	NV onshore project substation NV MA1	589285	311409
C	Existing Field and Residential Access	NG OHLM	588482	310789
D	Existing Field and Residential Access	NG OHLM	588882	311088
D1	Existing Field Access	NG OHLM	588668	310932

2.1 Access A – Existing Necton Electricity Substation Access

Access A was historically used by farmers to access the field south of the A47. In 2014 the access was upgraded to accommodate construction vehicle access for the National Grid and Dudgeon Offshore Windfarm substations collectively known as the Necton Electricity Substation (NES). The upgrade

comprised a simple T junction with grasscrete 'over-run' for abnormal loads. Construction work for the NES was completed by early 2017.

At present the access is currently shared by local farmers accessing farmland and by operational and maintenance vehicles in servicing the NES.

2.2 Access B – Existing Farm Access

Access B is a field and farm access leading south east off the A47. It comprises of a loose gravel track allowing access to various farmland and farm buildings.

2.3 Access C – Existing Field and Residential Access

Access C is a metalled access with a short driveway leading to a gated residential property. At this point the access track turns north east and runs parallel to the A47 through a wooded area for approximately 230m before entering the field with the electricity pylon. This access was proposed by National Grid as their preferred access point.

2.4 Access D – Existing Residential and Field Access

Access D is a field access located on Moor Lane approximately 270m north west of its junction with the A47. The A47/Moor Lane junction is a metalled bellmouth junction leading to a single vehicle track. Moor Lane is used to access farmland, residential properties and a number of farm buildings. This access has been proposed as an alternative to Access C by National Grid.

2.5 Access D1 – Existing Field Access

Access D1 is an existing field access located on the northern verge of the A47 approximately 300 north east of the existing NES access. The access allows immediate access to the field with the electricity pylon. This access has been identified as an alternative to Access C during the course of this study.

3 Baseline Situation

3.1 Highway Environment

The A47 trunk road is identified in the Norfolk County Council (NCC) Local Transport Plan (Norfolk County Council, 2011) as one of Norfolk's key strategic connections and is part of the Strategic Road Network, managed by Highways England.

Within the A47 access study area, the A47 is a relatively straight single carriageway road of typical road width and alignment for a trunk road and is subject to the national speed limit with no street lights present. There is a slight hill with a gradient of approximately 3%. The crest of the hill is located approximately 200m to the northeast of the existing NES access.

The A47 is bounded to the north by established hedgerows, woodland and agricultural land. The existing NES and further agricultural land is located to the south of the A47 with a number of hedgerows that border along the extent of the southern A47 verge.

3.2 Background Traffic Data

Traffic flow data obtained from the Department of Transport confirms a 24 hour Annual Average Daily Flows (AADF) of 15,380 total vehicles including 1,546 HGV component.

Speed surveys were undertaken within the access study area during August and September 2017. The location of the surveys can be observed in **Figure 03**, the results of the speed surveys are detailed **Table 3.1**.

Table 3.1: Speed Survey Results

Speed Survey ID	Date	85 th Percentile (mph) Northbound	85 th Percentile (mph) Southbound
SS1	16.09.17 to 22.09.17	55.5	54.4
SS2	22.08.17 to 28.08.17	54.1	53.5

The results of the speed surveys indicate that vehicle speeds passing the proposed site access are below the posted 60mph speed limit with, a maximum 85th percentile of 55.5 mph recorded.

3.3 Personal Injury Collision (PIC) Data

To assess whether there are any inherent road safety issues within the access study area, detailed STATS19¹ data have been obtained from NCC for the five year period, 01.05.12 to 30.04.17. **Figure 03** details the location of the PICs within the access study area and **Appendix A** provides the STATS19 data.

A review of the STATS19 data has identified two collisions occurring on the A47 within the access study area. The first collision (PIC1) occurred north east of access A and C and involved a driver travelling eastbound who fell asleep at the wheel and veered into an oncoming car. The second collision (PIC2) involved a rear end shunt which occurred when vehicles travelling eastbound braked heavily in the vicinity of 'Spicers Corner' junction. Both collisions resulted in slight injuries.

From the analysis of PICs it is concluded that there is no inherent pattern of collisions identified. Furthermore, neither of the collisions involved HGV traffic and only one (PIC2) was located within 100m of a proposed access.

It should be noted the STATS19 data sourced covers the construction period for the Necton Electricity Substation.

¹ Accidents on the public highway that are reported to the police and which involve injury or death are recorded by the police on a STATS19 form. The form collects a wide variety of information about the accident (such as time, date, location, road conditions).

4 Norfolk Vanguard Traffic Demand

4.1 Vehicle Types

The vehicle types expected to access the Norfolk Vanguard infrastructure sites during construction will include:

- concrete trucks;
- tipper trucks;
- articulated low loader vehicles;
- cranes;
- Light Commercial Vehicles (LCVs);
- site plant; and
- Abnormal Indivisible Loads. (AILs).

Forecast vehicle trips during the project construction period have been extrapolated from the recently submitted Norfolk Vanguard Preliminary Environmental Information Report and are reproduced within **Table 4.1**.

Table 4.1 Norfolk Vanguard Traffic Demand

Norfolk Vanguard Work Activity	Daily Movements		Peak Hour Movements	
	LCVs	HGVs	LCVs	HGVs
Onshore Project Substation	40	58	20	6
National Grid Substation Extension*	40	26	20	3
MA 1 (Cable Route)	40	74	20	8
Totals	120	158	60	17
Total Vehicle Movements	278		77	
A total of 200 HGVs and 40 LCV movements will be required to access north off the A47 (Access C/D) to complete the * Overhead Line Modifications work. These movements would be conducted over two separate construction peaks lasting a week each and separated by a gap of four to six months.				

5 Access Standards

The required standard for each access location has been evaluated against the criteria set out in the Design Manual for Roads and Bridges (Department for Transport, 1995). **Table 5.1** summarises.

Table 5.1 DMRB Access Requirements

Access ID	Background AADT Flows		Forecast Daily Construction Flows		Existing Available Visibility (Compliant speed)			DMRB 'Right turn' Traffic Flow Criteria Met ¹	Does Existing Access meet DMRB standards?
	Tot Veh	HGV	Tot Veh	HGV	Left	Right	Vertical		
A	15,380	1,546	278	158	215m (60mph applicable)	215m (60mph applicable)	Yes	Yes – Right turn required	No
B					215m (60mph applicable)	150m (60mph applicable)	Yes		
C			24	20	215m (60mph applicable)	215m (60mph applicable)	Yes	Yes – Right turn required	No
D					113m (60mph applicable)	215m (60mph applicable)	Yes		
D1					215m (60mph applicable)	215m (60mph applicable)	No		

¹DMRB states that upgrading at existing simple junctions to provide a right turn should always be considered where the minor road flows exceed 500 vehicles 2-way AADT, a right turning accident problem is evident or where vehicles waiting on the major road to turn right inhibit the through flow and create a hazard. The key criteria stated in DMRB to provide a Ghost Island junction with a right turn facility includes the major road traffic flows exceeding 13,000 vehicles per day.

Table 5.1 shows that all five accesses currently do not conform to the standards set out in the DMRB for right-turning traffic to be accommodated and each would require engineering to be fully compliant with standards.

6 Access Reviews and Proposals.

A review of each access has been undertaken with reference to the information set out in **Sections 2, 3, 4 and 5**. An assessment of each option has been undertaken using the following parameters:

- Highway Safety;
- Environment; and
- Infrastructure requirement.

6.1 Access A Review

It is noted that the existing access arrangement is below the standard of what would be required for a modern trunk road access serving traffic of significant volumes of (side-road) traffic. To counteract this, a traffic management strategy was employed during the construction of the NES which precluded vehicles from making a right turn in, or right turn out of the site. Recognising these issues, Highways England has directed the following criteria must be met for the existing access to be considered with minimal modifications:

- 1) A review of PICs to evidence no patterns (clusters) attributable to the access design. The PIC review must cover the duration of the construction of the existing Necton Substation.
- 2) A forecast traffic demand no higher for the NES construction phase than that of the existing Necton sub-station.
- 3) A commitment from Norfolk Vanguard Limited to employ a 'no right turn traffic management strategy'.

To assist with the review, Royal HaskoningDHV has obtained anecdotal evidence from the NES substation construction contractors, Wilding Construction Ltd (WCL). WCL were responsible for site management of all partners involved in the construction of the NES (Siemens, Statoil, Laing O'Rourke and National Grid).

Criterion 1

Construction for the NES commenced in 2014 and was completed by early 2017. Construction activity peaked during summer 2016. **Section 3.3** of this report contains a review of PIC data covering these periods and concludes there was no-inherent highway safety issue.

Criterion 2

Section 4 confirms a forecast traffic demand for the construction of Norfolk Vanguard of 278 daily movements, consisting of 158 HGV movements and 120 light vehicle movements.

WCL feedback indicates at the height of the Construction works for the NES a total of 400 operatives and approximately 230 cars were accessing the site every day along with an average of 25-30 deliveries of various vehicle sizes from concrete lorries to tipper trucks.

The total NES daily peak construction traffic movements equates to approximately 520 movements per day (noting the HGV component is 60 movements).

This anecdotal evidence indicates that the forecast traffic flows for the Norfolk Vanguard Project could comfortably meet Criterion 2 albeit a higher HGV demand is predicted [to that of the NES].

Should the forecast higher HGV component be of concern to Highways England, daily movements could be controlled to NES levels by a Construction Traffic Management Plan but this would potentially impact on construction duration.

Criterion 3

The NES traffic management strategy consisted of an enforced restriction on right turns in and out of the site. This required HGV arrivals from the east to travel eastbound on the A47 turning off at the A1075 junction at Dereham and then returning westbound back to the Substation access. This journey would entail a diversion route totalling 15.5 miles.

HGV departures to the east would travel westbound to the 'McDonalds' Norwich Road Roundabout before 'u' turning and returning eastbound. This journey would entail a diversion route totalling 5.5 miles.

Light vehicles were also subject to the enforced restriction but had the option of a shorter eastbound diversion by utilising the layby at Spicers Corner to make a right turn to return westbound.

Feedback from WCL indicates the strategy (backed up with reporting and enforcement) was adhered to by all contractors (sub-station, cabling and National Grid).

If the NES traffic management strategy was applied to the Norfolk Vanguard Project, based on current forecasts this would lead to 79 HGVs per day making the 15.5 mile diversion via Dereham - a total increase of 1224.5 miles per day. This is likely to manifest in increased tender prices due to larger fleet sizes and fuel costs.

A further consideration is traffic growth subsequent to the NES consent (2012). It is conceivable that the characteristic of the highway network has changed as the economy has rallied in the region.

Specific to the diversion route, it is notable from site visits that Dereham has significant traffic congestion which particular impacts on two signalised junctions located at Tavern Lane/ Yaxham Road and Yaxham Road/ Greens Road. If NES traffic management strategy was to be implemented in the modern era it is recommended that a full assessment of capacity, delay, noise and air quality is undertaken for the Dereham diversion route.

To alleviate the restrictions associated with utilising the existing junction arrangement a standard DMRB² compliant design has been considered at this location (notated as Access A1).

The following subsections review Access A and A1 in context with the adopted study parameters.

Highway Safety

From a highway safety perspective, Access A currently provides the requisite highway visibility of 215m for a 60mph road in both directions. Within the visibility envelope the highway has a straight horizontal alignment with a slight gradient which rises to the eastbound. DMRB Compliant vertical visibility is achievable for Access A.

Access A1 would also achieve all the highway safety parameters as detailed for Access A.

Environmental Impact (Access A)

No significant vegetation clearance is required to obtain visibility splays. As previously noted, there are indirect environmental impact concerns with respect to the diversion route through Dereham.

Environmental Impact (Access A1)

From an ecology perspective, approximately 772m² of vegetation would need to be removed to allow for widening of the A47 and additional visibility splay envelopes. The timescales would be dictated by seasonal constraints.

Infrastructure Requirements (Access A1 only)

The following infrastructure improvements would be required:

- Removal of the existing grasscrete.
- Widening of the A47 carriageway to include a right turn lane and ghost island facility.
- Removal of existing vegetation to allow for highway widening and visibility splays.
- Realignment and widening of existing access approach to cater for a 7.3m approach width allowing passing of two HGVs.
- Construction of new a new bellmouth with 15m corner radii (potentially wider for abnormal loads).

In addition, there will be increased costs related to traffic management to allow existing NES and farm traffic to continue to use the access.

² Design speed of 100km/h (60mph) including ghost island right turn facility with turning lane width of 3.5m and queuing storage length of 49.5m.

The widening of the A47 carriageway would occur within land under Norfolk Vanguard control or public highway and would require night time working over several weeks.

The design of the access should allow for infrequent ALLs to be delivered to site without further widening or strengthening work to be completed outside of the upgraded access envelope.

6.2 Access B Review

The current Access B is approximately 16m north of the existing Spicers Corner junction with the A47 to the north. The layout of these junctions creates a left-right stagger which is not compliant with DMRB standards.

Based on the current baseflows and forecast Norfolk Vanguard project construction flows, Access B would require upgrading to a DMRB standard compliant access. A new access point would need to be created approximately 68m to the south west of the existing access to create a DMRB³ compliant right-left stagger with a minimum 50m distance between both junction centrelines.

The following subsections review Access B in context with the adopted study parameters.

Highway Safety

From an existing highway perspective, there has been no collision patterns identified as described in Section 3.3. Access B would be standard compliant and meet all the required visibility splays for a 100kph design speed.

Environmental Impact

From an ecology perspective, the new access would require the removal of existing vegetation and the potential removal of a number of established trees. The vegetation clearance would encompass the whole of the visibility envelope and to the extents of the new access and A47 widening works this would comprise of approximately 750m² of land.

Infrastructure Requirements

The following infrastructure improvements would be required:

- Widening of the A47 carriageway to include a right turn lane and ghost island facility.
- Construction of a new access to incorporate a bellmouth with 15m corner radii and a 7.3m approach width allowing passing of two HGVs (potentially wider for abnormal loads).
- Additional internal track to tie back into the substation access track.

³ Design speed of 100km/h (60mph) including ghost island right turn facility with turning lane width of 3.5m and queuing storage length of 49.5m.

The required visibility of 215m to the east would be achieved following relocation of the access 68m further south and the widening works on the southern verge of the land within Norfolk Vanguard control or public highway land.

The construction works would require night time working with substantial temporary traffic management required over several weeks.

The design of the access should allow for infrequent ALLs to be delivered to site without further widening or strengthening work to be completed outside of the upgraded access envelope.

6.3 Access C and D Review

The following subsections review Accesses C, D and D1 in context with the adopted study parameters.

Highway Safety

From a highway safety perspective Access C could achieve the requisite 215m visibility splays with vegetation cutback in both directions. Access D would require the cutback/remove approximately 100m of established hedgerow to the east to be compliant. Both accesses are situated on relatively straight roads on a hill with approximately a 3% gradient.

Both Access C and Access D would introduce conflicts with either existing farm or residential traffic and neither the access track (Access C) or Moor Lane (Access D) would allow two way HGV traffic movements. At both access locations vehicles exiting the A47 may have to wait for traffic departing the access points onto the A47. This has the potential of causing vehicles to queue back from these pinch points causing an obstruction to the A47 flow of traffic.

Recognising these road safety concerns, a potential alternative access in this vicinity has been identified (notated as D1). Access D1 is an existing field access 334m northeast of Access D with direct access to the field with the electricity pylon. The access could be widened and two-way HGV movements would be possible with no sharing of road space with existing farm traffic or other public vehicles.

Horizontal visibility is good (215m) in both directions. Vertical visibility is compromised approaching the junction from both directions with a minimum vertical height achievable of 0.48m from the west and 0.33m from the east. These heights are based on the height above the carriageway an approaching motorist can view over the hill crest to the access from a stopping sight distance of 215m (100kph design speed). These measurements do not meet the required 0.26m minimum height detailed in the DMRB and therefore Access D1 would require a speed restriction to achieve the desired forward visibility.

Environmental Impact

From an ecology perspective, all the accesses would require the removal of existing vegetation and the potential removal of a number of established trees. The vegetation clearance would encompass the whole of the visibility envelope.

Infrastructure Requirements

There is minimal scope for junction widening at Access C and D to allow the safe two-way movements of construction HGVs. Access C is constrained by an immediate right hand bend, while Access D is constrained by private properties and a drainage ditch to the north of the access route.

Access D1 has greater scope for junction improvements and would require the following infrastructure improvements:

- Removal of existing vegetation to allow for visibility splays.
- Widening of existing access approach to cater for a 6m approach width allowing passing of two HGVs.
- Construction of new a new bellmouth with 10m corner radii.

Proposed Access Management Strategy

A total of 200 HGVs and 40 LCVs would be required to access the Electricity Pylon field to complete the OHLM works. The works would be subject to two construction peaks of between 1-4 weeks with a 4-6 month gap between each peak.

It is therefore considered that constructing a DMRB compliant right-turn access would be disproportional to the traffic demand. As an alternative, it is proposed to implement an Access Management Strategy for the duration of the OHLM works. The Access Management Strategy would eradicate right turn maneuverers on the A47 by enforcing left in, left out manoeuvres to minimise infrastructure provision. and would include options based on which substation access (A or B) is taken forward.

All OHLM traffic would check in at the main NGSE works using Access A or A1. Traffic would then exit left out of Access A or A1 and perform a u-turn manoeuvre at the roundabout junction between the A47 and Norwich Road. A left turn in to either Access C, D or D1 could then be completed. This strategy would require an approximate 4.5mile diversion for a forecast 240 vehicles and could be enforced within the CTMP.

7 Summary and Conclusions

Table 7.1 provides a summary of the Norfolk Vanguard Project access review and applies a simple scoring system to differentiate between option.

Table 7.1. Access Scoring summary

Access Options	Highway Safety	Environmental Impacts	Infrastructure Requirements	Totals	Comments
A	2	2	5	9	<ul style="list-style-type: none"> - Requires u-turn traffic management strategy approval. - Potential capacity, delay, noise and air quality impacts within Dereham associated with diversion route.
A1	5	3	1	9	DMRB compliant access, significant engineering and environmental works required.

B	5	3	1	9	DMRB compliant access, significant engineering and environmental works required.
C	1	2	3	6	<ul style="list-style-type: none"> - Requires u-turn access management strategy approval. - Potential highway safety concern for A47 traffic associated with narrow access/egress.
D	1	2	4	7	<ul style="list-style-type: none"> - Requires u-turn access management strategy approval. - Potential highway safety concern for A47 traffic associated with narrow access/egress.
D1	4	2	3	9	<ul style="list-style-type: none"> - Requires u-turn access management strategy approval. - Requires a temporary speed limit for the duration of the OHLM works.
Highway safety scoring system used 1-5 (1 indicates low safety, 5 indicates high safety).					
Environmental impacts scoring system used 1-5 (1 indicates major impact, 5 indicates minimal impact).					
Infrastructure requirements scoring system used 1-5 (1 indicates greatest total cost, 5 indicates least total cost).					

For the project infrastructure sites south of the A47, Accesses A, A1 and B all score identical.

It is considered that the traffic management stipulations associated with Access A would have a significant impact on the efficient construction of the sub-station which in turn represents an economical risk. Access A1 and B have substantial infrastructure costs associated with implementing a standard compliant design.

Notwithstanding, based on the road safety and environmental impact assessment, there are no overriding reasons to reject any of these three access options. Furthermore, there are no overriding technical/policy constraints preventing both Access A/A1 and B being utilised, rather, there are potential road safety benefits in removing vehicle conflicts between Substation and NGES/OHLM works.

With regard to the OHLM works, Accesses C and D have constrained access/egress which give rise to safety concerns on the A47. Access D1 is the clear preferred option, but will require an approval of a temporary speed limit for the duration of the works.

APPENDICES

APPENDIX A
STATS 19 Data

Five years to end April 2017

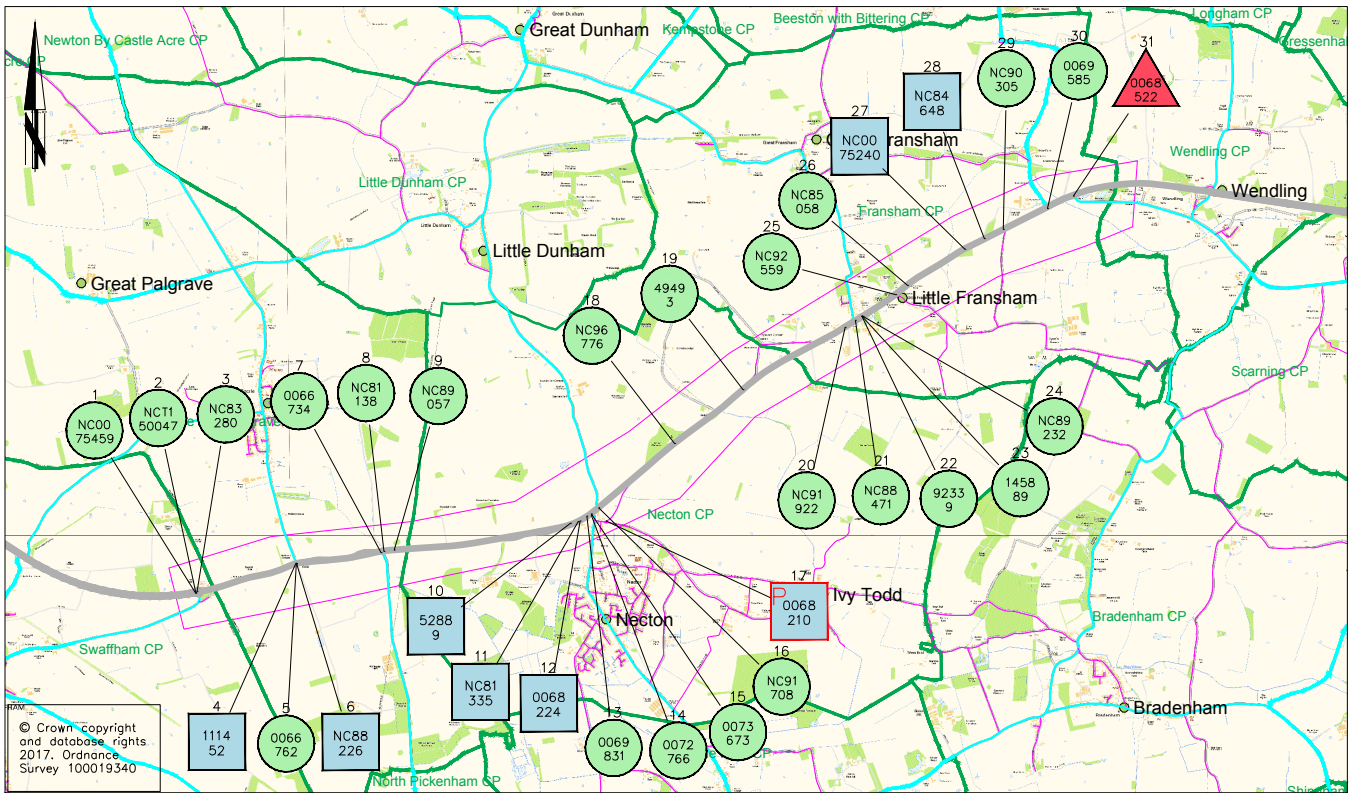

Reference Number	1 NC00 75459	2 NCT1 50047	3 NC83 280	4 1114 52	5 0066 762	5a 0066 762	6 NC88 226	7 0066 734	8 NC81 138	9 NC89 057	10 5288 9	11 NC81 335	12 0068 224	13 0069 831	14 0072 766	15 0073 673
Date / Day	Fr 01	We 11	Mo 25	Fr 30	Fr 10		Th 19	Fr 03	Mo 09	Sa 21	We 09	Mo 23	Th 29	Mo 04	Su 14	Tu 20
Month	Nov	Mar	Aug	Sep	Aug		Feb	Aug	Jun	Aug	Mar	Jun	Nov	Mar	Jul	Aug
Year	2013	2015	2014	2016	2012		2015	2012	2014	2015	2016	2014	2012	2013	2013	2013
Time	1300	0845	1500	1733	0640		1115	1445	0845	1303	0638	2207	0920	1040	1915	1139
Severity	SI	SI	SI	Se	SI		Se	SI	SI	SI	Se	Se	Se	SI	SI	SI
Dark / Lit																
Weather Conditions																
Road Surface																
Special Conditions																
Carriageway Hazards																
Vehicle Manoeuvres																
Vehicle 1	5e															
Vehicle 2	6t															
Vehicle 3	7c															
Vehicle 4	8															
Casualty / age																

Reference Number	16 NC91 708	17 NCT1 50047	18 NC83 280	19 1114 52	20 0066 762	21 0066 762	22 NC88 226	23 0066 734	24 NC81 138	25 NC89 057	26 5288 9	27 NC81 335	28 0068 224	29 0069 831	30 0072 766	31 0073 673
Date / Day	Fr 03	Tu 04	Tu 08	Su 07	Sa 11	We 04	We 06	Tu 29	Fr 27	We 05	Su 26	Th 24	Tu 14	Mo 11	Th 14	Mo 24
Month	Jul	Dec	Dec	Feb	Jul	Mar	Jul	Nov	Mar	Aug	Oct	Oct	Oct	May	Feb	Dec
Year	2015	2012	2015	2016	2015	2015	2016	2016	2015	2015	2014	2013	2014	2015	2013	2012
Time	1514	1630	0856	1100	1600	1640	0745	0815	0750	1322	1235	2250	0640	1717	1010	1430
Severity	SI	Se	SI	SI	SI	SI	SI	SI	SI	SI	SI	Se	Se	SI	SI	Fa
Dark / Lit																
Weather Conditions																
Road Surface																
Special Conditions																
Carriageway Hazards																
Vehicle Manoeuvres																
Vehicle 1	5e															
Vehicle 2	6t															
Vehicle 3	7c															
Vehicle 4	8															
Casualty / age	39 42	16	21	59	62 60 60 60	64	49 47	35	29	62	52 11 17 40	17	31	42	22	77 69

Full Details Report Summary -

Accidents Found Date Range: 03/08/2012 - 29/11/2016

Grid Coordinate Range: 584290,309490 - 592050,313000

Accident Date BETWEEN '01-May-2012' AND '30-Apr-2017'

Accident Severity

	2012	2013	2014	2015	2016	Total
Fatal	1	0	0	0	0	1
Serious	2	1	2	1	2	8
Slight	2	5	3	9	3	22
Total	5	6	5	10	5	31

Casualty Severity

	2012	2013	2014	2015	2016	Total
Fatal	3	0	0	0	0	3
Serious	2	1	2	1	2	8
Slight	4	6	7	18	4	39
Total	9	7	9	19	6	50

Casualty KSI

	2012	2013	2014	2015	2016	Total
Adult KSI	5	1	2	1	2	11
Slight	4	6	7	18	4	39
Total	9	7	9	19	6	50

Accident Date BETWEEN '01-May-2012' AND '30-Apr-2017'

1.3 Accident Reference: NC96776 Slight NECTON, A47 APPROX 450MTRS SOUTH WEST OF MOOR LANE Accident 18 of 31

1.7 Date & 1.9 Time.....Tuesday 08/12/2015 08:56	1.15 Speed limit.....60 Mph
1.11 Grid co-ordinates.....588525/310812	1.14 Road type.....Single c'way
1.10 Local Authority.....Breckland	1.16 Junction detail.....Not at or within 20m of junction
1.12/1.13 1st road identity..A47	1.17 Junction control.....
1.18/1.19 2nd road identity..	1.24 Special conditions...None
1.22 Weather.....Rain	1.25 Carriageway hazards..None
1.21 Light conditions.....Daylight	1.5 Number of vehicles...2
1.20a Crossing(human).....No Human control within 50m	1.6 Number of casualties.1
1.20b Crossing(physical).....No crossing facility within 50m	1.23 Surface.....Wet

Did a police officer attend?
Yes

Accident Description

V1 ON A47 HEADED TOWARDS NORWICH WHEN DRIVER OF V1 FELL ASLEEP AT WHEEL DRIFTED ACROSS C/WAY AND HIT V2 IN OPPOSITE DIRECTION

2 Vehicles

2.4 Veh ref no.....1	2.16 First impact.....Offside
2.17 Other vehicle.....0	2.12 Hit object in c'way..None
2.5 Vehicle class.....Car	2.14 Hit object off c'way.None
2.10 Junction location...Not at junction	2.18 Parts damaged..... / /
2.9 Restricted location.On main carriageway	2.21 Driver gender.....Male
2.8 Movement from/to....South west North east	2.22 Driver age.....25
2.7 Manoeuvres.....Going ahead other	
2.11 Skidding.....No	2.24 Hit and Run.....No
2.13 Left c'way.....Left c'way Offside	2.23 Breath test.....Negative
2.6 Towing.....No	2.29 Journey purpose.....Commuting to/from work
2.28 Foreign vehicle.....Not foreign	

2.4 Veh ref no.....2	2.16 First impact.....Offside
2.17 Other vehicle.....0	2.12 Hit object in c'way..None
2.5 Vehicle class.....Car	2.14 Hit object off c'way.None
2.10 Junction location...Not at junction	2.18 Parts damaged..... / /
2.9 Restricted location.On main carriageway	2.21 Driver gender.....Male
2.8 Movement from/to....North east South west	2.22 Driver age.....21
2.7 Manoeuvres.....Going ahead other	
2.11 Skidding.....No	2.24 Hit and Run.....No
2.13 Left c'way.....Did not leave c'way	2.23 Breath test.....Negative
2.6 Towing.....No	2.29 Journey purpose.....Commuting to/from work
2.28 Foreign vehicle.....Not foreign	

1 Casualty

3.5 Cas ref no.....1	3.15 Car passenger.....No
3.6 Casualty class.....Driver or Rider	3.16 PSV passenger.....No
3.7 Gender.....Male	3.14 Seat belt usage.....Worn but not independently
3.8 Age.....21	3.13 Medical pupil.....Other (3.19 School
3.9 Severity.....Slight	3.10 Pedestrian location..Not a pedestrian
3.4 Vehicle no.....2	3.11 Pedestrian movement..Not a pedestrian
3.12 Ped Direction.....Not a pedestrian	3.19 Roadworker injured...No

Accident Date BETWEEN '01-May-2012' AND '30-Apr-2017'

1.3 Accident Reference:49493 Slight A47

Accident 19 of 31

1.7 Date & 1.9 Time.....Sunday 07/02/2016 11:00	1.15 Speed limit.....60 Mph
1.11 Grid co-ordinates.....589129/311289	1.14 Road type.....Single c'way
1.10 Local Authority.....King's Lynn and West Norfolk	1.16 Junction detail.....Not at or within 20m of junction
1.12/1.13 1st road identity..A47	1.17 Junction control.....
1.18/1.19 2nd road identity..	1.24 Special conditions...None
1.22 Weather.....Unknown	1.25 Carriageway hazards..None
1.21 Light conditions.....Daylight	1.5 Number of vehicles...2
1.20a Crossing(human).....No Human control within 50m	1.6 Number of casualties.1
1.20b Crossing(physical).....No crossing facility within 50m	1.23 Surface.....Dry

Did a police officer attend?
No - reported over the counter

Accident Description

VEH2 IN A LINE OF TRAFFIC ON THE A47 TRAVELLING TOWARDS FRANSHAM. THE LINE OF TRAFFIC BRAKED HEAVILY AS DID VEH2, BUT VEH1 COLLIDED WITH THE REAR OF VEH2 CAUSING WHIPLASH INJURIES TO THE PASSANGER IN THE FRONT OF VEH2.

2 Vehicles

2.4 Veh ref no.....1	2.16 First impact.....Front
2.17 Other vehicle.....0	2.12 Hit object in c'way..None
2.5 Vehicle class.....Car	2.14 Hit object off c'way.None
2.10 Junction location...Not at junction	2.18 Parts damaged..... / /
2.9 Restricted location.On main carriageway	2.21 Driver gender.....Male
2.8 Movement from/to....East West	2.22 Driver age.....-1
2.7 Manoeuvres.....Going ahead other	
2.11 Skidding.....No	2.24 Hit and Run.....No
2.13 Left c'way.....Did not leave c'way	2.23 Breath test.....Not contacted
2.6 Towing.....No	2.29 Journey purpose.....Unknown
2.28 Foreign vehicle.....Not foreign	

2.4 Veh ref no.....2	2.16 First impact.....Back
2.17 Other vehicle.....0	2.12 Hit object in c'way..None
2.5 Vehicle class.....Car	2.14 Hit object off c'way.None
2.10 Junction location...Not at junction	2.18 Parts damaged..... / /
2.9 Restricted location.On main carriageway	2.21 Driver gender.....Not known
2.8 Movement from/to....East West	2.22 Driver age.....60
2.7 Manoeuvres.....Going ahead other	
2.11 Skidding.....No	2.24 Hit and Run.....No
2.13 Left c'way.....Did not leave c'way	2.23 Breath test.....Not contacted
2.6 Towing.....No	2.29 Journey purpose.....Unknown
2.28 Foreign vehicle.....Not foreign	

1 Casualty

3.5 Cas ref no.....1	3.15 Car passenger.....Front
3.6 Casualty class.....Passenger	3.16 PSV passenger.....No
3.7 Gender.....Female	3.14 Seat belt usage.....Unknown
3.8 Age.....59	3.13 School pupil.....Other (3.19 School
3.9 Severity.....Slight	3.10 Pedestrian location..Not a pedestrian
3.4 Vehicle no.....2	3.11 Pedestrian movement..Not a pedestrian
3.12 Ped Direction.....Not a pedestrian	3.19 Roadworker injured...No

FIGURES

FIGURE 1
Site Location

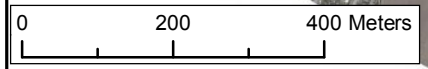
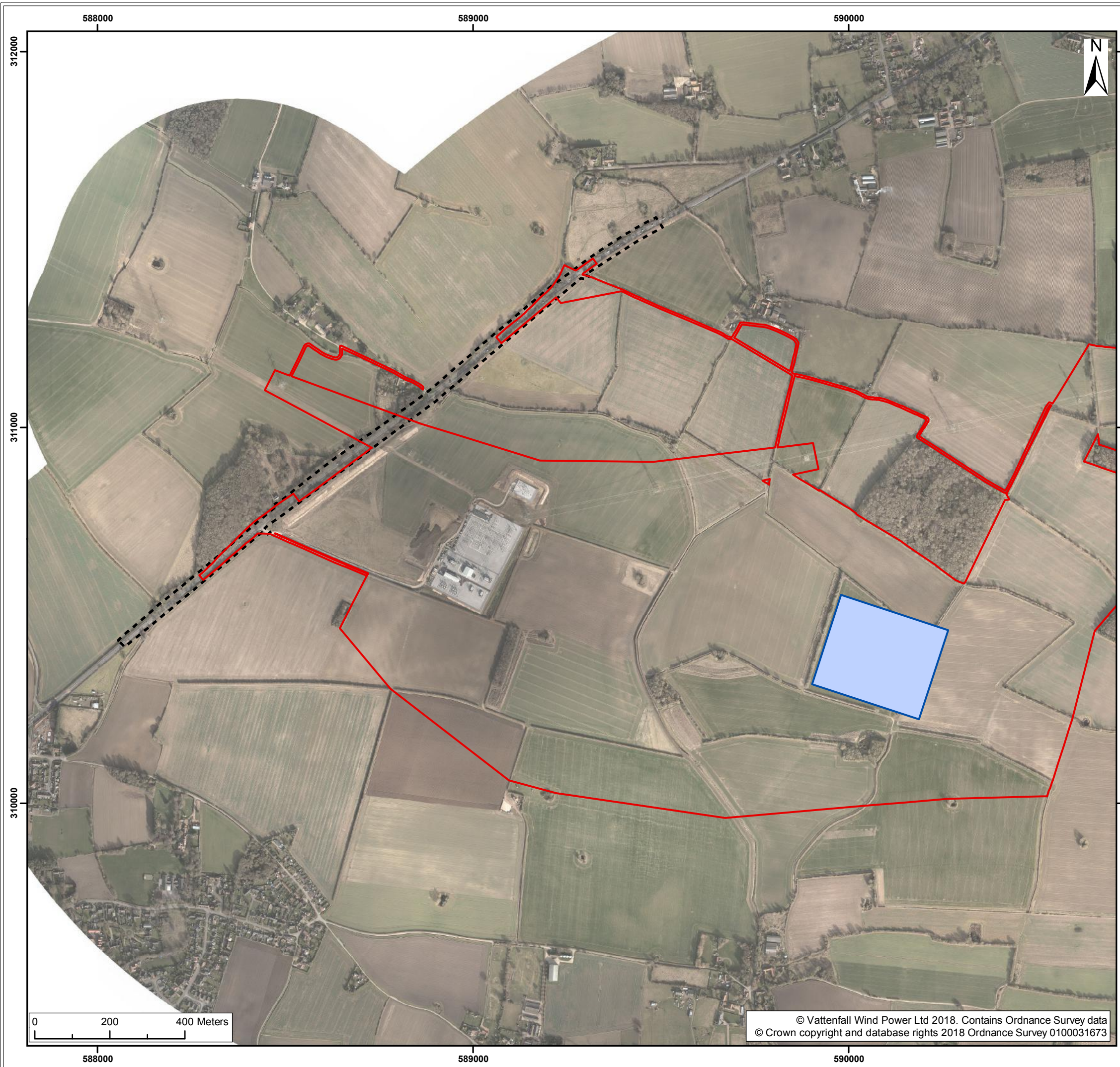

© Vattenfall Wind Power Ltd 2018. Contains Ordnance Survey data
 © Crown copyright and database rights 2018 Ordnance Survey 0100031673

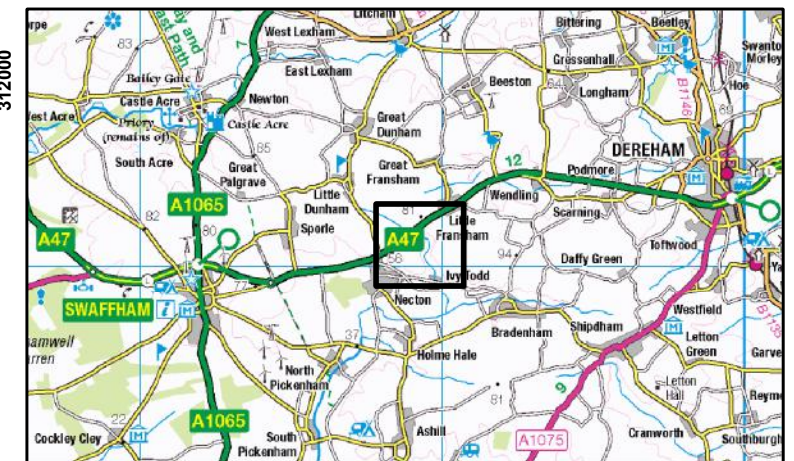

- Legend:
- Proposed Norfolk Vanguard onshore project substation
 - Red Line Boundary
 - A47 Access Study Area

Note:
 PMAI to be located within Red Line Boundary
 at a location to be determined

Project:	Report:
Norfolk Vanguard	A47 Access Review

Title:
 Site Location Plan

Figure: 1	Drawing No: PB4476-003-00X-001				
Revision:	Date:	Drawn:	Checked:	Size:	Scale:
01	12/01/2018	GC	RE	A3	1:10,000

Co-ordinate system: British National Grid EPSG: 27700



FIGURE 2
Access Options

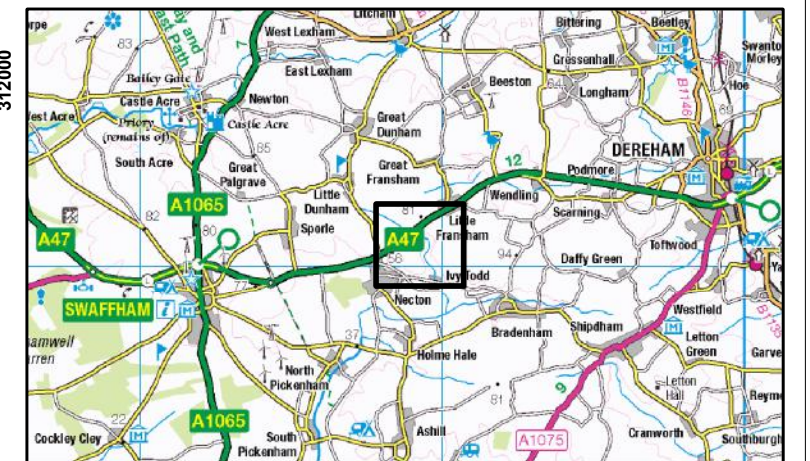
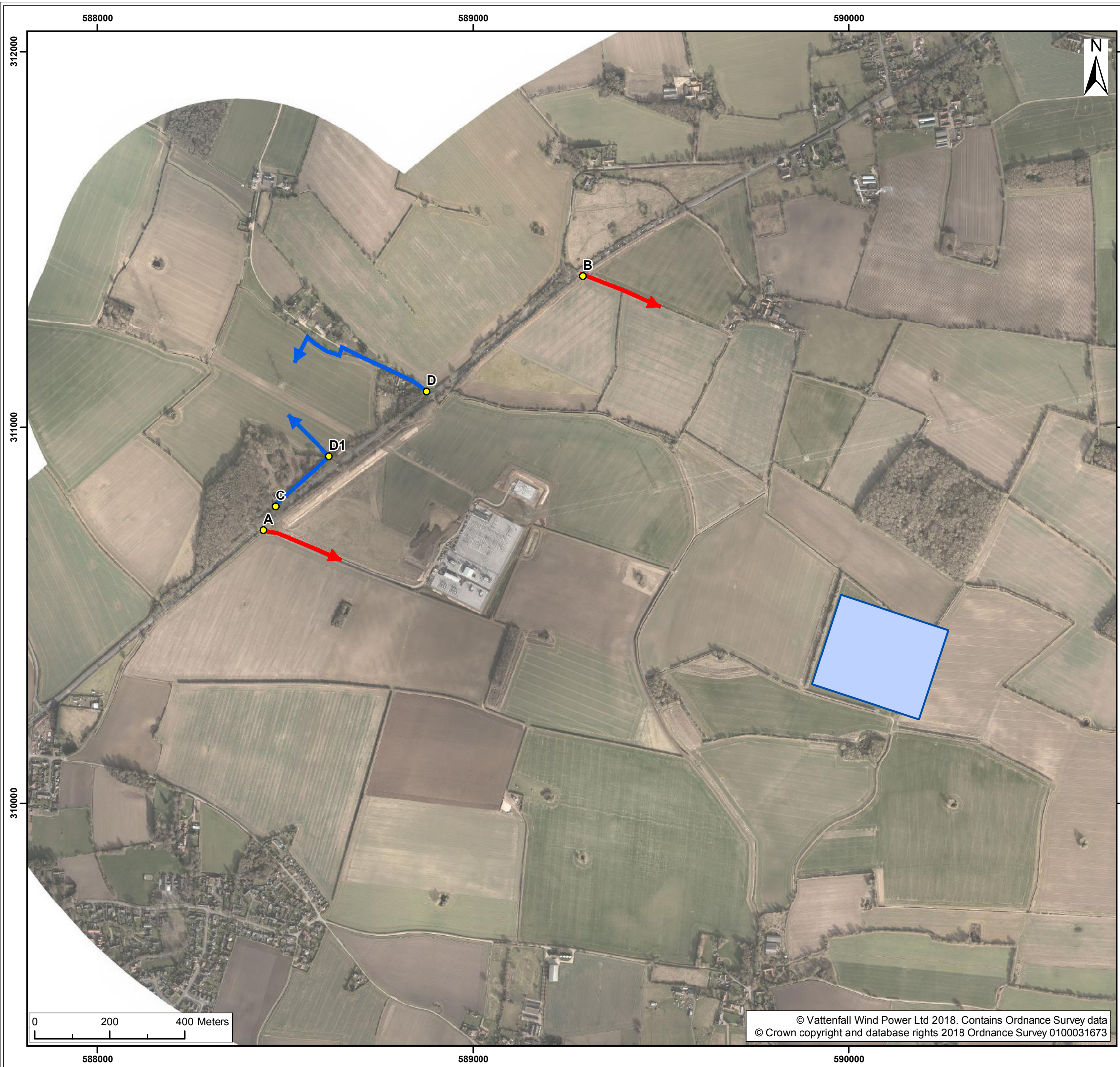

- Legend:
- Proposed Norfolk Vanguard onshore project substation
 - Access Point ID
 - Access Options for National Grid Overhead Line Modification Works
 - Access Options for Norfolk Vanguard Onshore Project Substation and National Grids Substation Extension

Project:	Report:
Norfolk Vanguard	A47 Access Review

Title:

Access Options

Figure:	2	Drawing No:	PB4476-003-00X-002		
Revision:	Date:	Drawn:	Checked:	Size:	Scale:
01	12/01/2018	GC	RE	A3	1:10,000

Co-ordinate system: British National Grid EPSG: 27700



© Vattenfall Wind Power Ltd 2018. Contains Ordnance Survey data
 © Crown copyright and database rights 2018 Ordnance Survey 0100031673

FIGURE 3

Speed Survey and Personal Injury Collision Locations

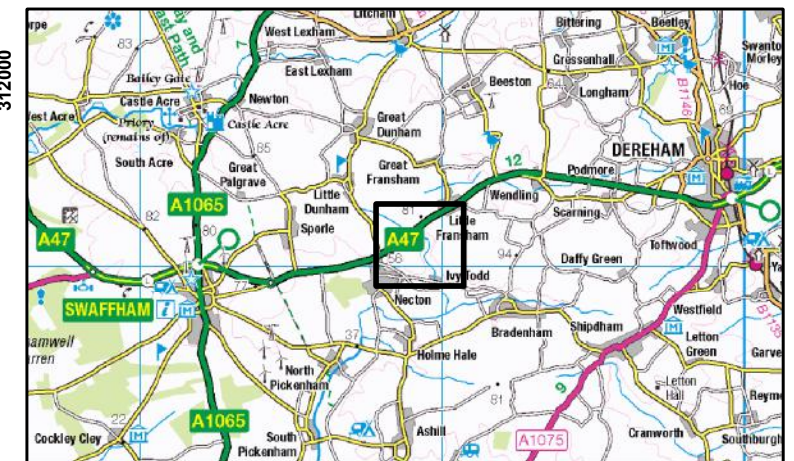

- Legend:
- Proposed Norfolk Vanguard onshore project substation
 - A47 Access Study
 - Access Point ID
 - Injury Collision Location
 - Speed Survey Locations

Project:	Report:
Norfolk Vanguard	A47 Access Review

Title:
Speed Survey and Personal Injury Collision Locations

Figure: 3	Drawing No: PB4476-003-00X-003				
Revision:	Date:	Drawn:	Checked:	Size:	Scale:
01	12/01/2018	GC	RE	A3	1:10,000

Co-ordinate system: British National Grid EPSG: 27700



Appendix 2: Access Design Concepts

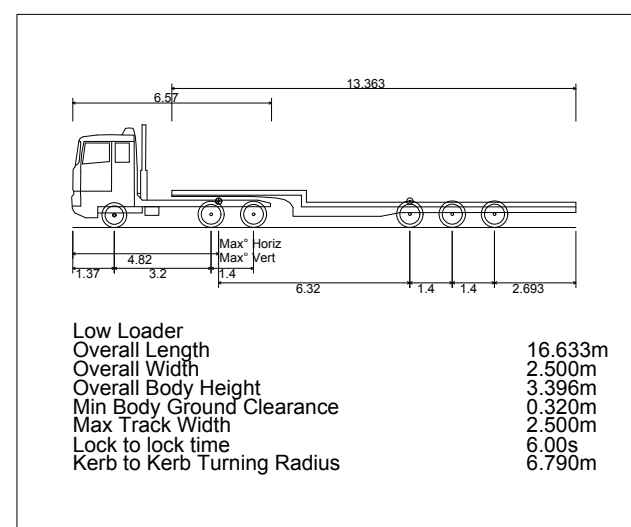
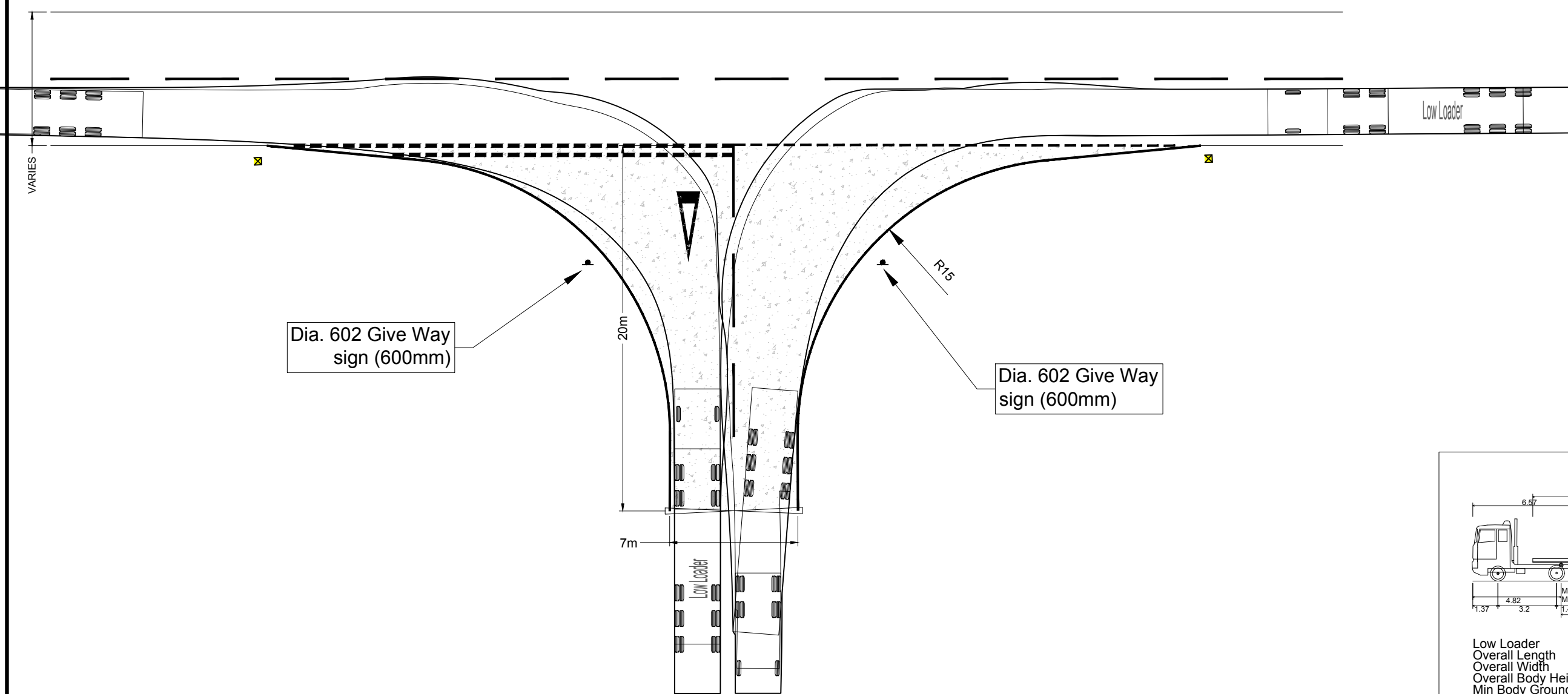
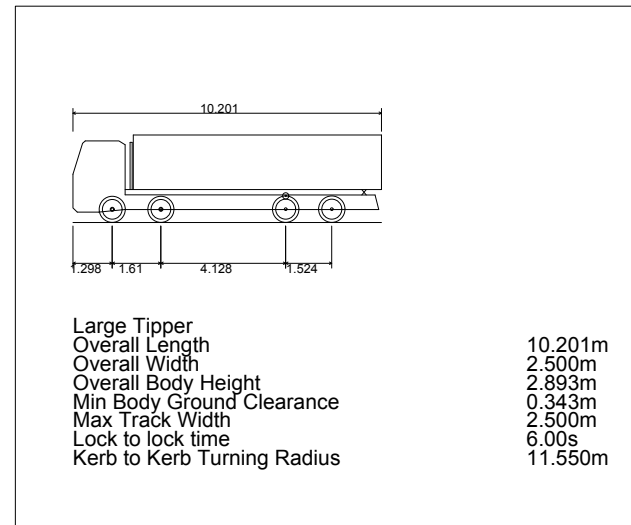
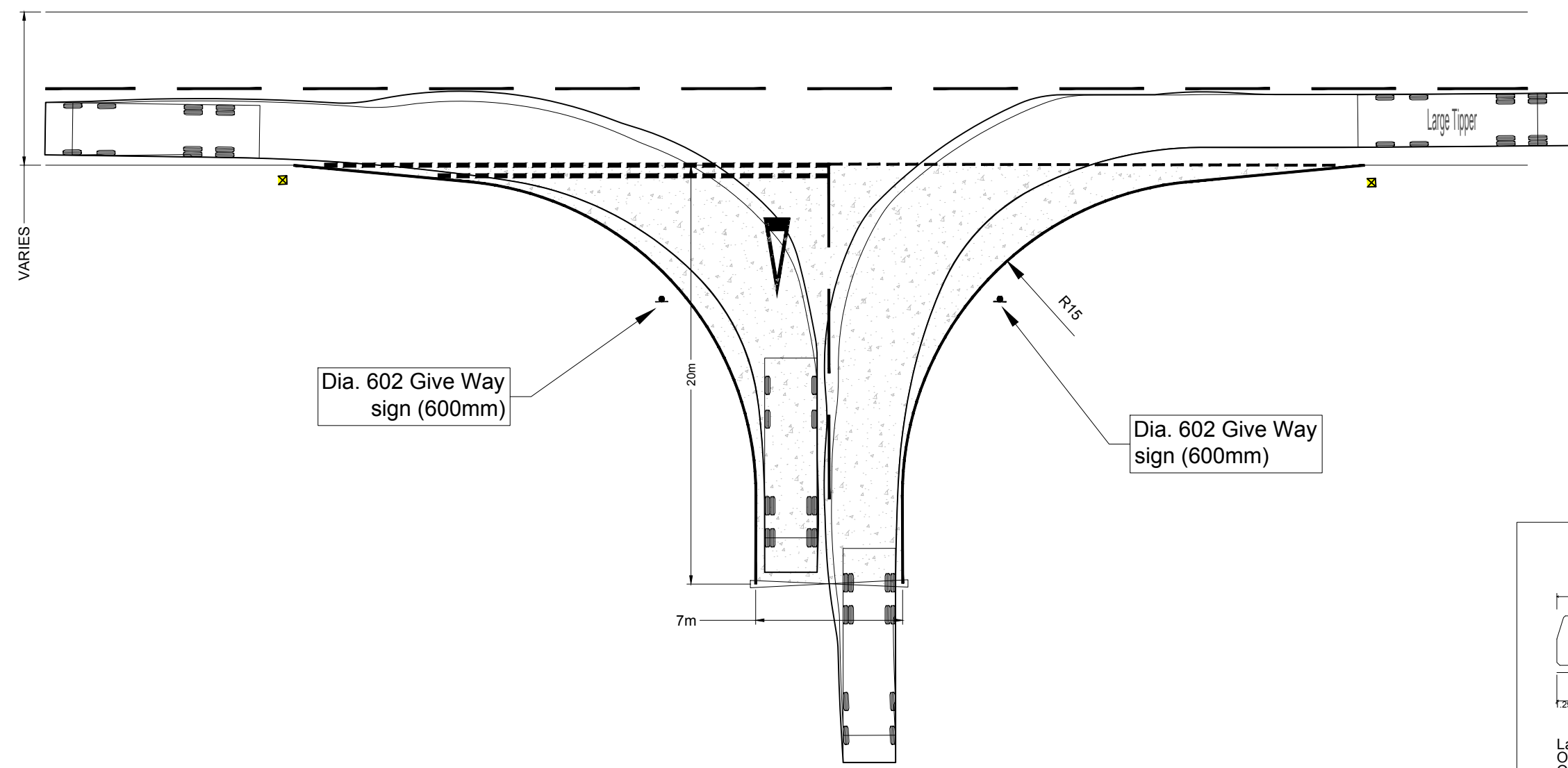

- NOTES**
- Do not scale from this drawing, all dimensions are in metres unless noted otherwise.
 - Exact junction types to be determined from relevant section of Design Manual for Roads & Bridges (TD 42/95).

- KEY**
- EXISTING METEALED ROAD BOUNDARY
 - PROPOSED ACCESS BOUNDARY/ROAD MARKINGS
 - PROPOSED GATE
 - PROPOSED PLASTIC DEMARCATION BOLLARD
 - PROPOSED POST MOUNTED TRAFFIC SIGN
 - PROPOSED ACCESS CONSTRUCTION

DRAFT - NOT FOR CONSTRUCTION

REV	DATE	DESCRIPTION	BY	CHK	APP
-----	------	-------------	----	-----	-----

REVISIONS

CLIENT



PROJECT
NORFOLK VANGUARD
OFFSHORE WIND FARM

TITLE
TYPE A ACCESS
DMRB A/B ROAD JUNCTION
20t TIPPER & LARGE LOW LOADER



DRAWN	BKB	CHECKED	RNE	APPROVED	ADR
-------	-----	---------	-----	----------	-----

DATE	SCALE AT A1	CLIENTS REF.
APR 2018	1:250	

DRAWING No.	PB4476-DR-H1-D-0100	REVISION
CLIENT DWG No.		-

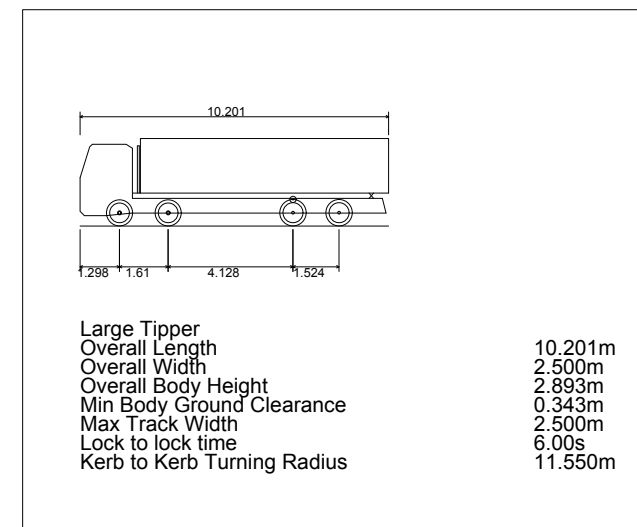
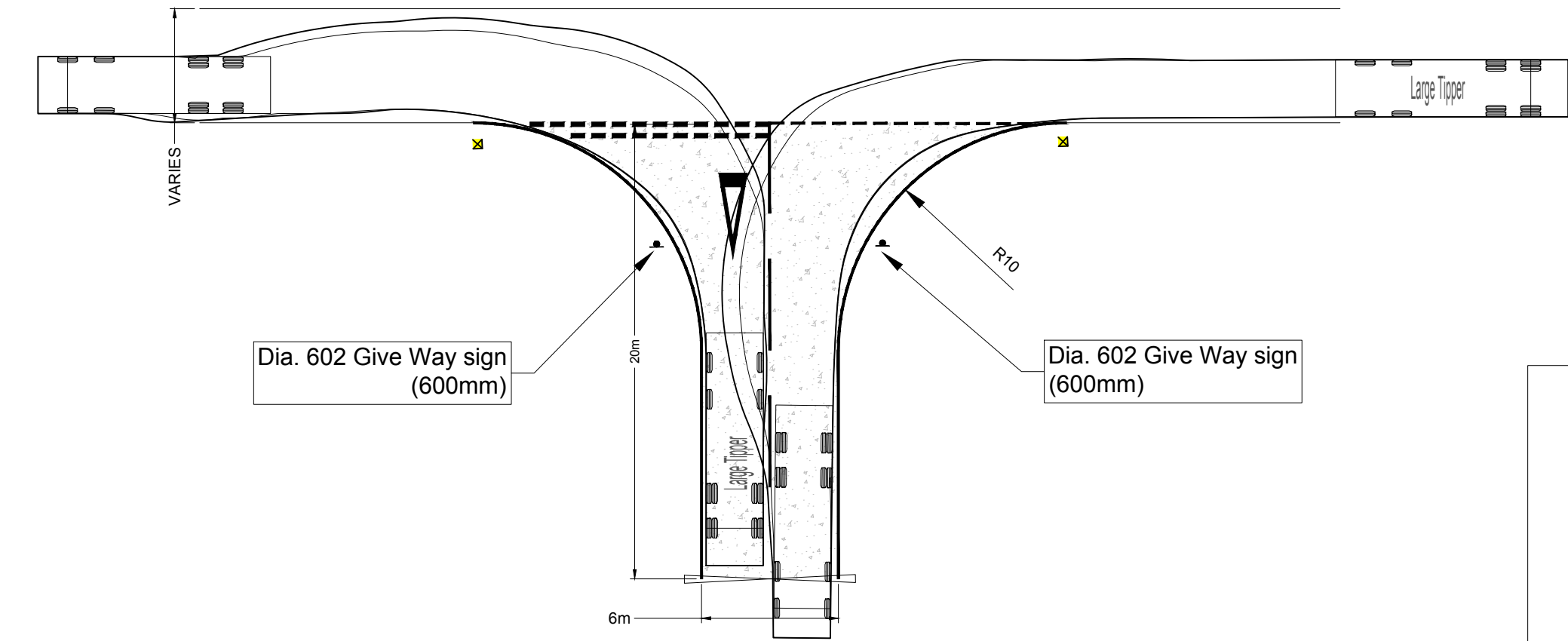

TYPE B ACCESS - RIGID VEHICLE
SWEPT PATH ANALYSIS

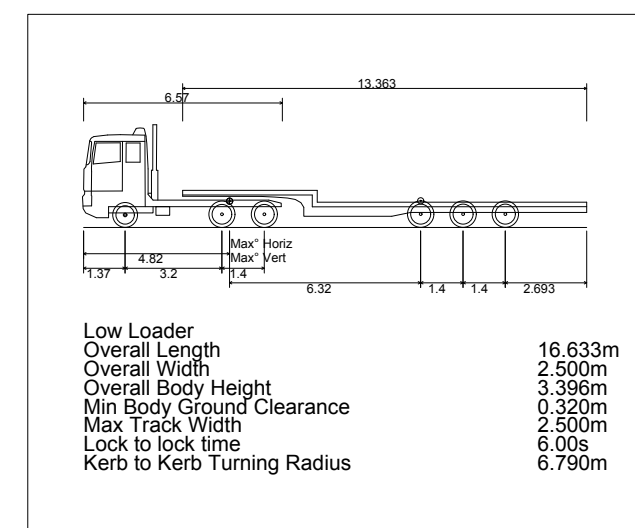
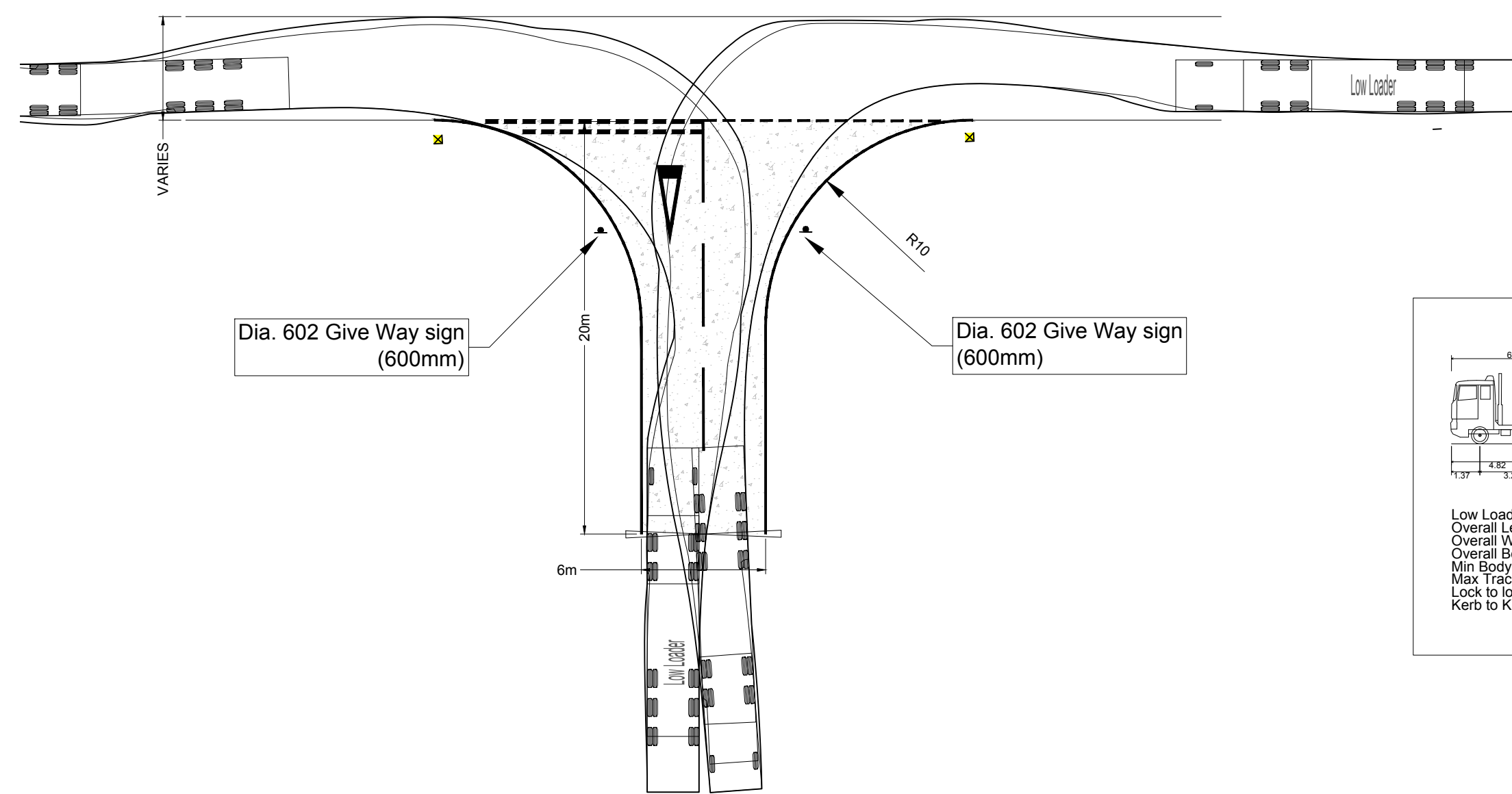

TYPE B ACCESS - LOW LOADER
SWEPT PATH ANALYSIS

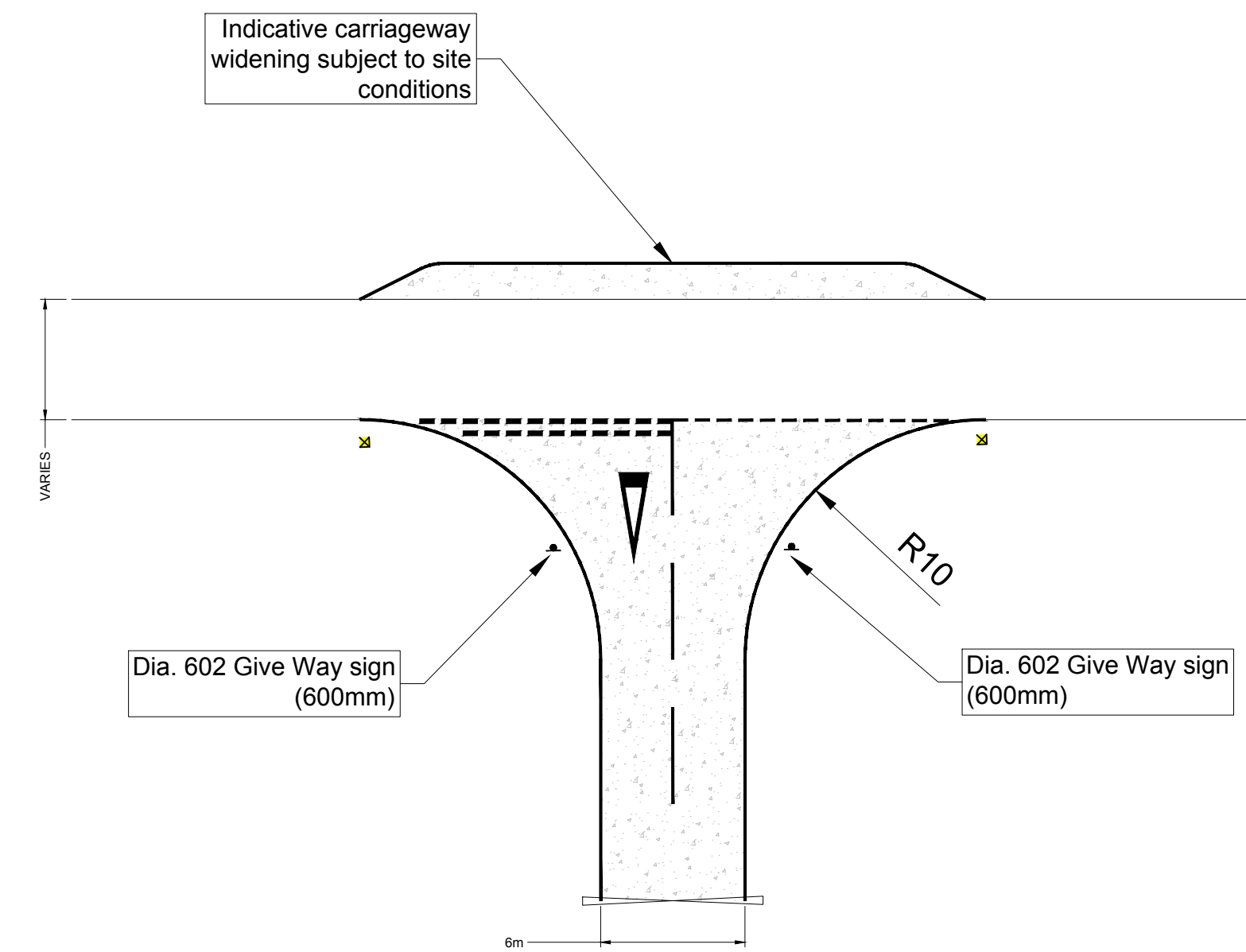

TYPE C ACCESS WITH OPPOSITE
VERGE WIDENING

NOTES

- Do not scale from this drawing, all dimensions are in metres unless noted otherwise.
- Final design subject to micro-siting and a review of vehicle requirements.
- Exact junction types to be determined from relevant section of Design Manual for Roads & Bridges (TD 42/95).

KEY

- EXISTING METEALED ROAD BOUNDARY
- PROPOSED ACCESS BOUNDARY/ROAD MARKINGS
- PROPOSED GATE
- ✕ PROPOSED PLASTIC DEMARCATION BOLLARD
- PROPOSED POST MOUNTED TRAFFIC SIGN
- ▨ PROPOSED ACCESS CONSTRUCTION

**DRAFT - NOT FOR
CONSTRUCTION**

REV	DATE	DESCRIPTION	BY	CHK	APP

REVISIONS

CLIENT



PROJECT

NORFOLK VANGUARD

TITLE

TYPE B & C ACCESS
REDUCED JUNCTION WITH 20t
TIPPER & LARGE LOW LOADER



DRAWN	CHECKED	APPROVED
BKB	RNE	ADR

DATE	SCALE AT A1	CLIENTS REF.
APR 2018	1:250	

DRAWING No.	REVISION
PB4476-DR-H1-D-0101	

CLIENT DWG No.	

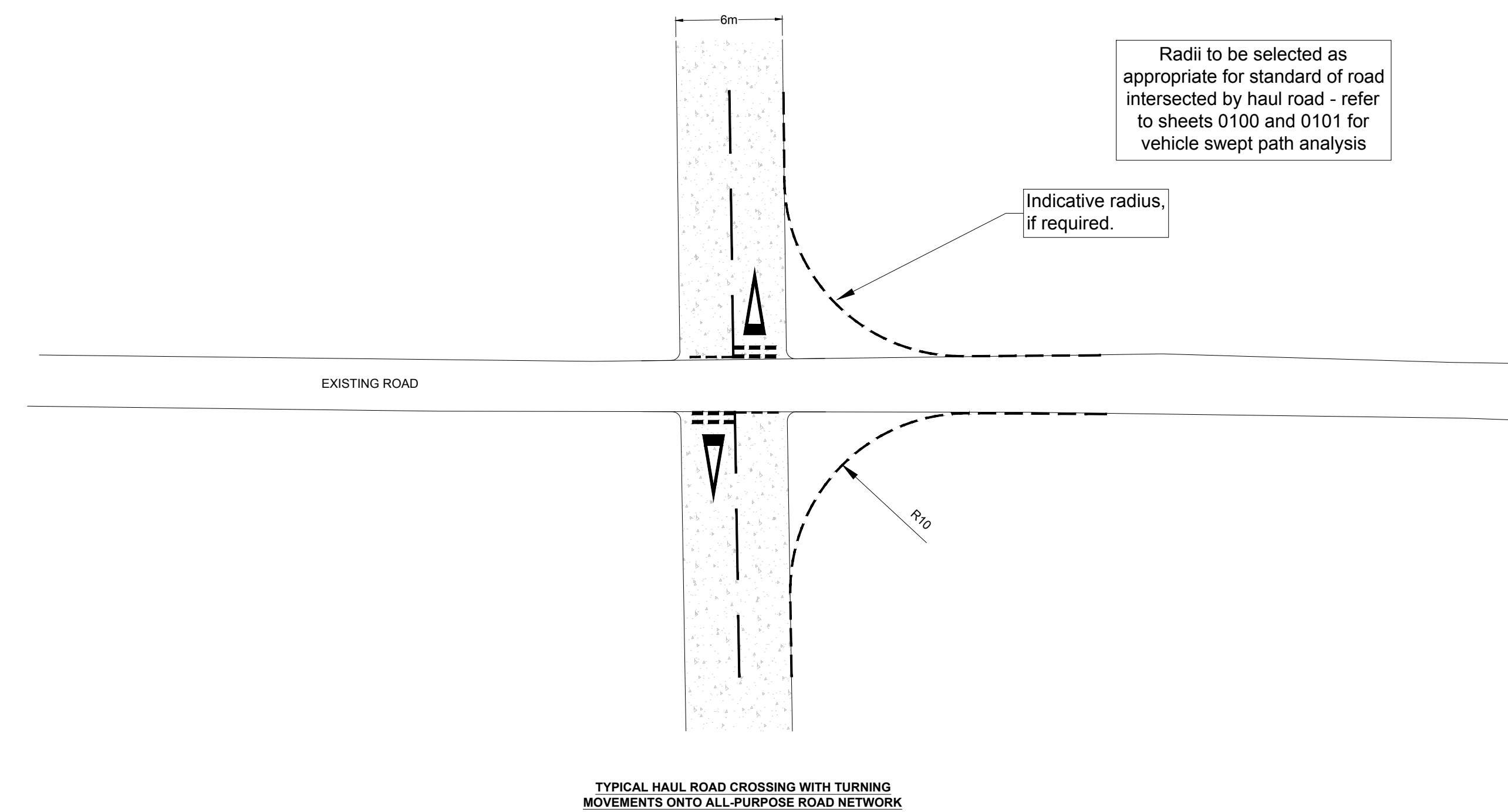
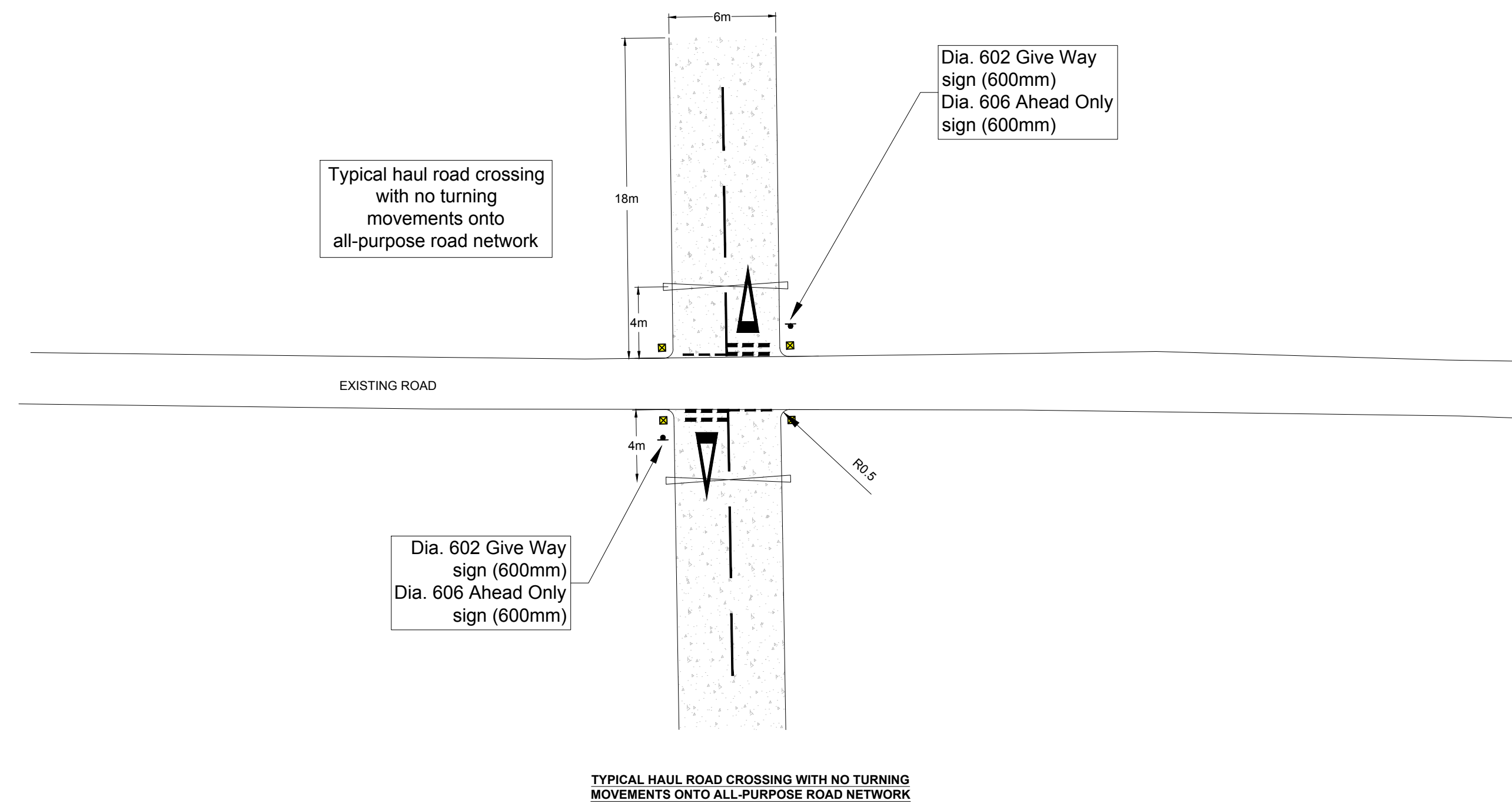

NOTES

- Do not scale from this drawing, all dimensions are in metres unless noted otherwise.
- Exact junction types to be determined from relevant section of Design Manual for Roads & Bridges (TD 42/95).

- KEY**
- EXISTING METALED ROAD BOUNDARY
 - PROPOSED ACCESS BOUNDARY/ROAD MARKINGS
 - PROPOSED GATE
 - PROPOSED PLASTIC DEMARCATION BOLLARD
 - ▲ PROPOSED POST MOUNTED TRAFFIC SIGN
 - ▨ PROPOSED ACCESS CONSTRUCTION

DRAFT - NOT FOR CONSTRUCTION

REV	DATE	DESCRIPTION	BY	CHK	APP
REVISIONS					
CLIENT					
					
PROJECT					
NORFOLK VANGUARD					
TITLE					
TYPE D ACCESS TYPICAL ROAD CROSSINGS					
					
DRAWN	BKB	CHECKED	RNE	APPROVED	ADR
DATE	APR 2018	SCALE AT A1	1:250	CLIENTS REF.	
DRAWING No.	PB4476-DR-H1-D-0102				REVISION
CLIENT DWG No.					-

